



# Installation, Start-Up and Service Instructions

## CONTENTS

	Page
<b>SAFETY CONSIDERATIONS</b> .....	1,2
<b>INSTALLATION</b> .....	2-17
<b>Step 1 — Provide Unit Support</b> .....	2
• ROOF CURB	
• ALTERNATE UNIT SUPPORT	
• SLAB MOUNT	
<b>Step 2 — Remove Shipping Rails</b> .....	2
<b>Step 3 — Rig and Place Unit</b> .....	2
• POSITIONING	
• ROOF MOUNT	
• INSTALLATION ONTO CURB	
<b>Step 4 — Field Fabricate Ductwork</b> .....	9
<b>Step 5 — Make Unit Duct Connections</b> .....	9
• VERTICAL CONFIGURATION	
• HORIZONTAL APPLICATIONS	
<b>Step 6 — Install Flue Hood and Inlet Hood</b> .....	10
<b>Step 7 — Trap Condensate Drain</b> .....	10
<b>Step 8 — Install Gas Piping</b> .....	10
<b>Step 9 — Make Electrical Connections</b> .....	11
• FIELD POWER SUPPLY	
• FIELD CONTROL WIRING	
<b>Step 10 — Install Outdoor-Air Hood</b> .....	12
• MANUAL DAMPER ASSEMBLY	
<b>Step 11 — Position Optional Power Exhaust or Barometric Relief Damper Hood</b> .....	16
<b>Step 12 — Non-Fused Disconnect</b> .....	16
<b>Step 13 — Install All Accessories</b> .....	16
<b>PRE-START-UP</b> .....	18
<b>START-UP</b> .....	18-45
Unit Preparation .....	18
Compressor Mounting .....	18
Refrigerant Service Ports .....	18
Crankcase Heater(s) .....	18
Compressor Rotation .....	18
Internal Wiring .....	18
Subcooler Heat Exchanger (SHX) .....	18
Evaporator Fan .....	18
Condenser Fans and Motors .....	19
Return-Air Filters .....	19
Outdoor-Air Inlet Screens .....	19
Gas Heat .....	19
Optional EconoMi\$er IV .....	39
Operating Sequence .....	44
<b>SERVICE</b> .....	46-57
Cleaning .....	46
Lubrication .....	47
Manual Outdoor Air Damper .....	48
Economizer Adjustment .....	48
Evaporator Fan Service and Replacement .....	48
Evaporator Fan Performance Adjustment .....	48
Evaporator Fan Belt Tension Adjustment .....	48
Condenser Fan Adjustment .....	49
Verify Sensor Performance .....	49
Economizer Operation During Power Failure .....	49
Evacuation .....	49
Refrigerant Charge .....	50
Gas Valve Adjustment .....	50
High Altitude .....	51
Main Burners .....	51
Filter Drier .....	52
Protective Devices .....	52
Relief Devices .....	52

	Page
<b>Control Circuit, 24-V</b> .....	52
<b>Replacement Parts</b> .....	52
<b>Diagnostic LEDs</b> .....	52
<b>TROUBLESHOOTING</b> .....	57-61
<b>Unit Troubleshooting</b> .....	57
<b>EconoMi\$er IV Troubleshooting</b> .....	60
<b>Phase Loss Protection</b> .....	61
<b>UNIT START-UP CHECKLIST</b> .....	CL-1

## SAFETY CONSIDERATIONS

Installation and servicing of air-conditioning equipment can be hazardous due to system pressure and electrical components. Only trained and qualified service personnel should install, repair, or service air-conditioning equipment.

Untrained personnel can perform the basic maintenance functions of cleaning coils and filters and replacing filters. All other operations should be performed by trained service personnel. When working on air-conditioning equipment, observe precautions in the literature, tags and labels attached to the unit, and other safety precautions that may apply.

Follow all safety codes. Wear safety glasses and work gloves. Use quenching cloth for unbrazing operations. Have fire extinguishers available for all brazing operations.

**⚠ WARNING**

Before performing service or maintenance operations on unit, turn off main power switch to unit. Electrical shock could cause personal injury.

**⚠ CAUTION**

Puron (R-410A) refrigerant systems operate at higher pressures than standard R-22 systems. Do not use R-22 service equipment or components on Puron refrigerant equipment. If service equipment is not rated for Puron refrigerant, equipment damage or personal injury may result.

**⚠ WARNING**

1. Improper installation, adjustment, alteration, service, or maintenance can cause property damage, personal injury, or loss of life. Refer to the User's Information Manual provided with this unit for more details.
2. Do not store or use gasoline or other flammable vapors and liquids in the vicinity of this or any other appliance.

**What to do if you smell gas:**

1. DO NOT try to light any appliance.
2. DO NOT touch any electrical switch, or use any phone in your building.
3. IMMEDIATELY call your gas supplier from a neighbor's phone. Follow the gas supplier's instructions.
4. If you cannot reach your gas supplier, call the fire department.

**⚠ WARNING**

Disconnect gas piping from unit when pressure testing at pressure greater than 0.5 psig. Pressures greater than 0.5 psig will cause gas valve damage resulting in hazardous condition. If gas valve is subjected to pressure greater than 0.5 psig, it *must* be replaced before use. When pressure testing field-supplied gas piping at pressures of 0.5 psig or less, a unit connected to such piping must be isolated by closing the manual gas valve(s).

**IMPORTANT:** Units have high ambient operating limits. If limits are exceeded, the units will automatically lock the compressor out of operation. Manual reset will be required to restart the compressor.

**INSTALLATION**

**Step 1 — Provide Unit Support**

**ROOF CURB** — Assemble or install accessory roof curb in accordance with instructions shipped with this accessory. See Fig. 1. Install insulation, cant strips, roofing, and counter flashing as shown. Ductwork can be installed to roof curb before unit is set in place. Ductwork must be attached to curb and not to the unit. Curb must be level. This is necessary to permit unit drain to function properly. Unit leveling tolerance is  $\pm 1/16$  in. per linear ft in any direction. Refer to Accessory Roof Curb Installation Instructions for additional information as required. When accessory roof curb is used, unit may be installed on class A, B, or C roof covering material. Carrier roof curb accessories are for flat roofs or slab mounting.

**IMPORTANT:** The gasketing of the unit to the roof curb is critical for a watertight seal. Install gasket with the roof curb as shown in Fig. 1. Improperly applied gasket can also result in air leaks and poor unit performance. Do not slide unit to position on roof curb.

**ALTERNATE UNIT SUPPORT** — When a curb cannot be used, install unit on a noncombustible surface. Support unit with sleepers, using unit curb support area. If sleepers cannot be used, support long sides of unit with a minimum of 3 equally spaced 4-in. x 4-in. pads on each side.

**SLAB MOUNT (Horizontal Units Only)** — Provide a level concrete slab that extends a minimum of 6 in. beyond unit cabinet. Install a gravel apron in front of condenser coil air inlet to prevent grass and foliage from obstructing airflow.

**NOTE:** Horizontal units may be installed on a roof curb if required.

**Step 2 — Remove Shipping Rails** — Remove shipping rails prior to lowering unit onto roof curb. See Fig. 2. The rails are attached to the unit at both the return end and condenser end. Remove the screws from both ends of each rail. Be careful not to drop the rails onto any surface that could be damaged. Discard the rails. It is important to replace the screws into the unit to avoid any air or water leakage.

**⚠ CAUTION**

Do not allow the shipping rail to drop on the roof surface. Damage to the roof surface may result.

**Step 3 — Rig and Place Unit** — Inspect unit for transportation damage. See Tables 1-3 for physical data. File any claim with transportation agency.

**⚠ CAUTION**

All panels must be in place when rigging. Unit is not designed for handling by fork truck. Damage to unit may result.

Do not drop unit; keep upright. Use spreader bars over unit to prevent sling or cable damage. Rollers may be used to move unit across a roof. Level by using unit frame as a reference; leveling tolerance is  $\pm 1/16$  in. per linear ft in any direction. See Fig. 3 for additional information. Unit rigging weight is shown in Fig. 3.

Four lifting holes are provided in the unit base rails as shown in Fig. 3. Refer to rigging instructions on unit.

**POSITIONING** — Maintain clearance, per Fig. 4, around and above unit to provide minimum distance from combustible materials, proper airflow, and service access.

Do not install unit in an indoor location. Do not locate air inlets near exhaust vents or other sources of contaminated air. For proper unit operation, adequate combustion and ventilation air must be provided in accordance with Section 5.3 (Air for Combustion and Ventilation) of the National Fuel Gas Code, ANSI Z223.1 (American National Standards Institute).

Although unit is weatherproof, guard against water from higher level runoff and overhangs.

Locate mechanical draft system flue assembly at least 4 ft from any opening through which combustion products could enter the building, and at least 4 ft from any adjacent building (or per local codes). When unit is located adjacent to public walkways, flue assembly must be at least 7 ft above grade.

**ROOF MOUNT** — Check building codes for weight distribution requirements. Unit operating weight is shown in Table 1.

**INSTALLATION ONTO CURB** — The 48PG units are designed to fit on either the accessory full perimeter curb. Correct placement of the unit onto the curb is critical to operating performance. To aid in correct positioning,  $3/8$ -in. diameter locating holes have been added to the unit base rails. When placing the unit, these holes should line up with the roof curb edge as shown in Fig. 5 and 6, to assure proper duct opening alignment. For placement on the roof curb, use the alignment holes located approximately 2-in. from the end of the base rail on the return end of the unit. See labels on the side of the unit for more details.

**⚠ CAUTION**

Do not slide unit to position it when it is sitting on the curb. Curb gasketing material may be damaged and leaks may result.

ROOF CURB ACCESSORY	CURB HEIGHT	DESCRIPTION	C		D	
			IN.	MM.	IN.	MM.
CRFCURB018C00	1.56"	ROOF CURB	3'-1.15/16"	976	9'-6.7/16"	1200
CRFCURB018C00	1.56"	ROOF CURB	3'-1.15/16"	976	9'-6.7/16"	1200
CRFCURB019C00	2.29"	ROOF CURB	3'-1.15/16"	976	9'-6.7/16"	1200
CRFCURB019C00	2.29"	ROOF CURB	3'-1.15/16"	976	9'-6.7/16"	1200

- NOTES:
1. ROOF CURB ACCESSORY IS SHIPPED DISASSEMBLED.
  2. DIMENSIONS IN ( ) ARE IN MILLIMETERS.
  3. DIRECTION OF AIRFLOW.
  4. ROOF CURB: 16 GA. (VA03-56) STEEL.
  5. TO PREVENT THE HAZARD OF STAGNANT WATER BUILD-UP IN THE UNIT.
  6. DO NOT EXCEED CURB LEVELING TOLERANCES.
  7. CLEARANCE BETWEEN UNIT BASE RAIL AND CURB FLANGE IS 1/4-IN. (6 MM) ON EACH SIDE.

MAX CURB LEVELING TOLERANCES:		A	B
ROOF CURB		DEG.	IN.
CRFCURB018C00		.28	.57
CRFCURB019C00		.28	.42

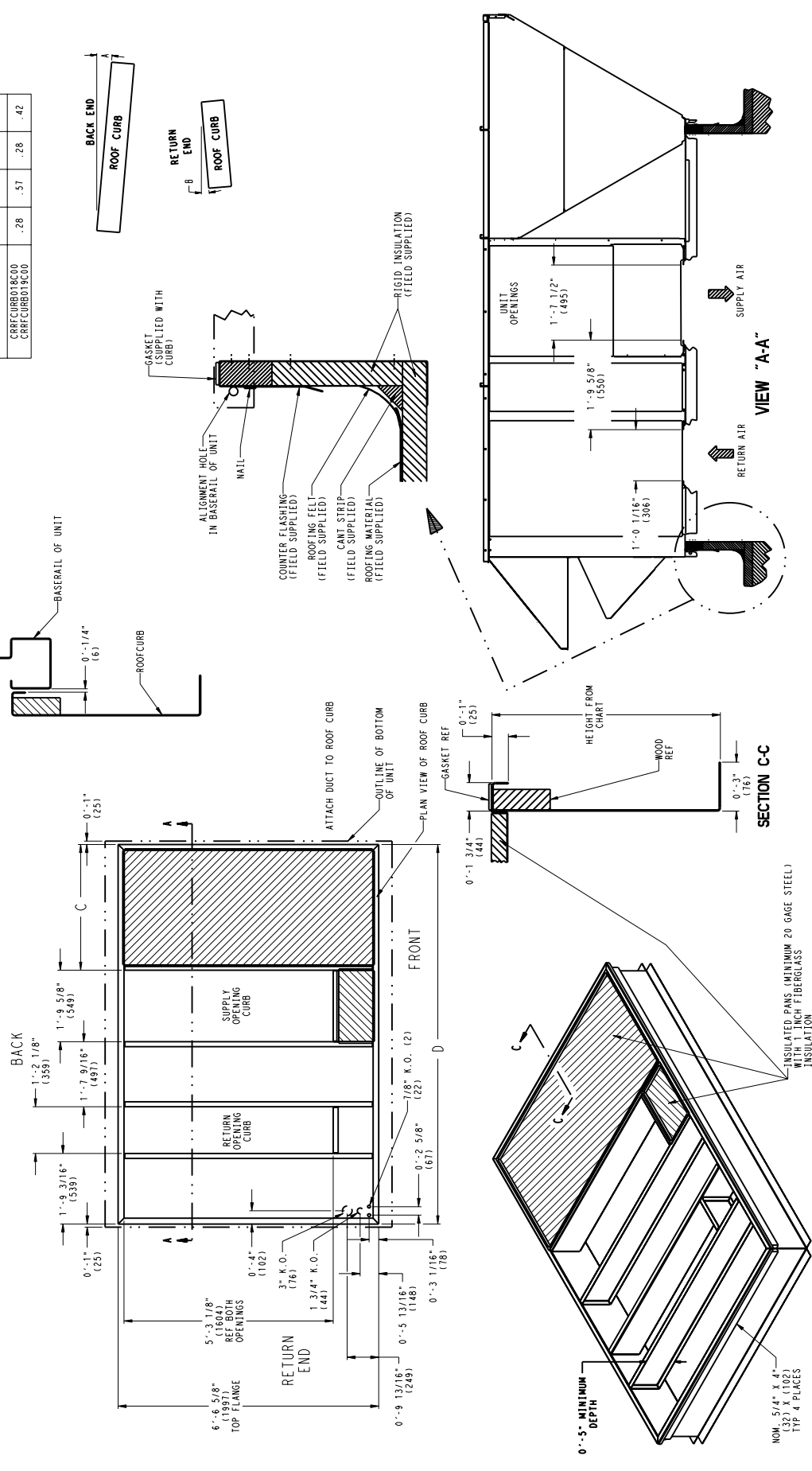
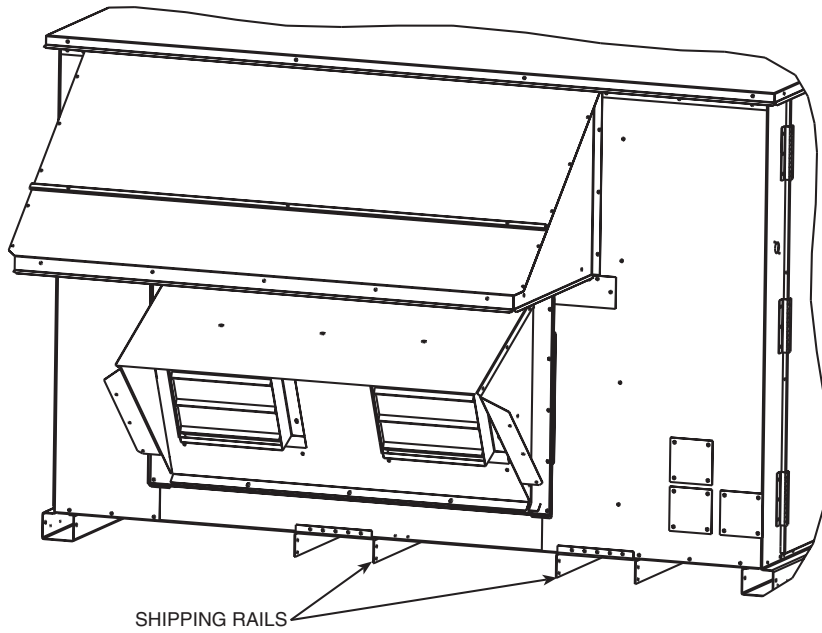


Fig. 1 — Roof Curb Details



**Fig. 2 — Shipping Rail Removal**

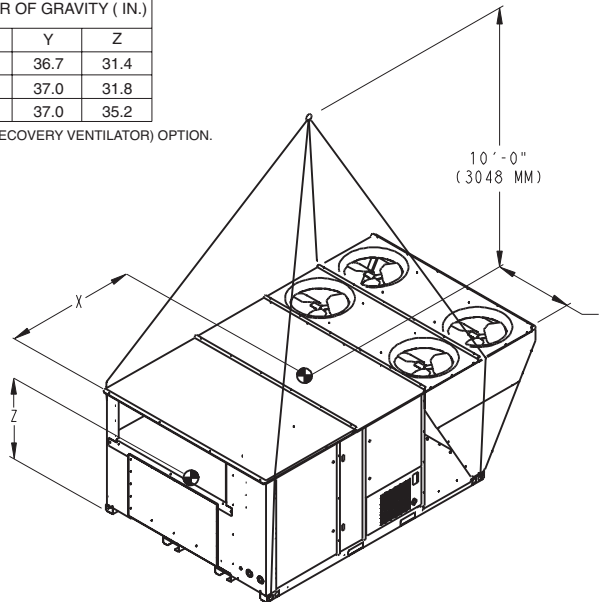


**CAUTION - NOTICE TO RIGGERS:**  
ALL PANELS MUST BE IN PLACE WHEN RIGGING.

**NOTICE TO RIGGERS:** Rig by inserting hooks into unit base rails as shown. Maintain a distance of 120 inches (3048 MM) from top of unit to eyehook. Leave coil cover attached to unit while rigging to protect coil of unit from damage.

UNIT SIZE	MAX WEIGHT (LB) *	CENTER OF GRAVITY ( IN. )		
		X	Y	Z
PG20	3825	66.5	36.7	31.4
PG24	4075	66.5	37.0	31.8
PG28	4300	70.5	37.0	35.2

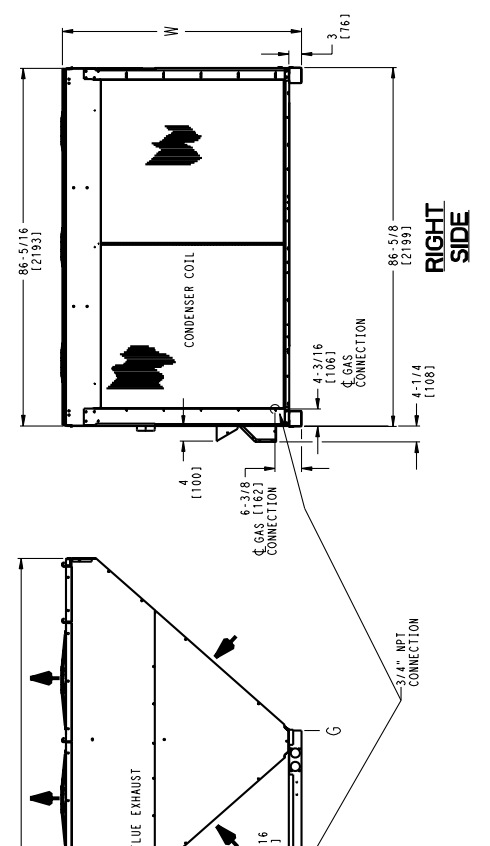
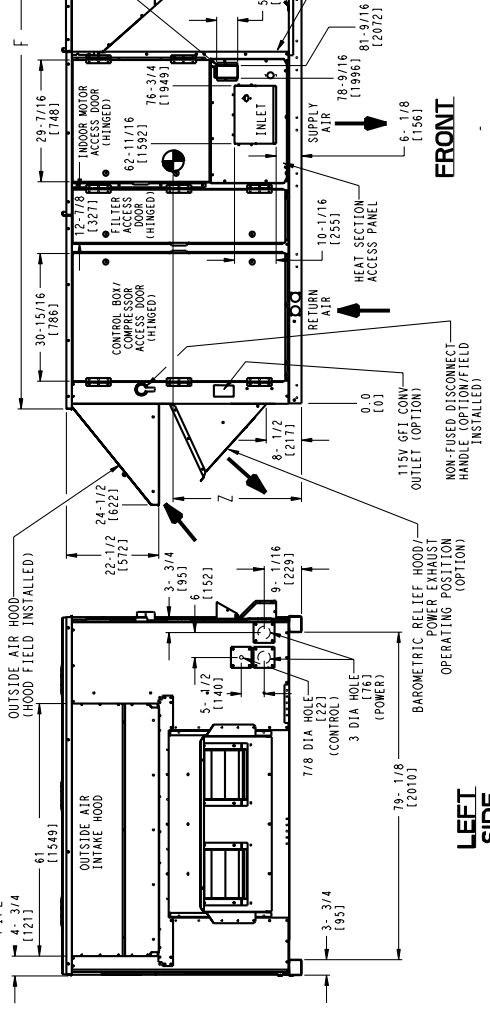
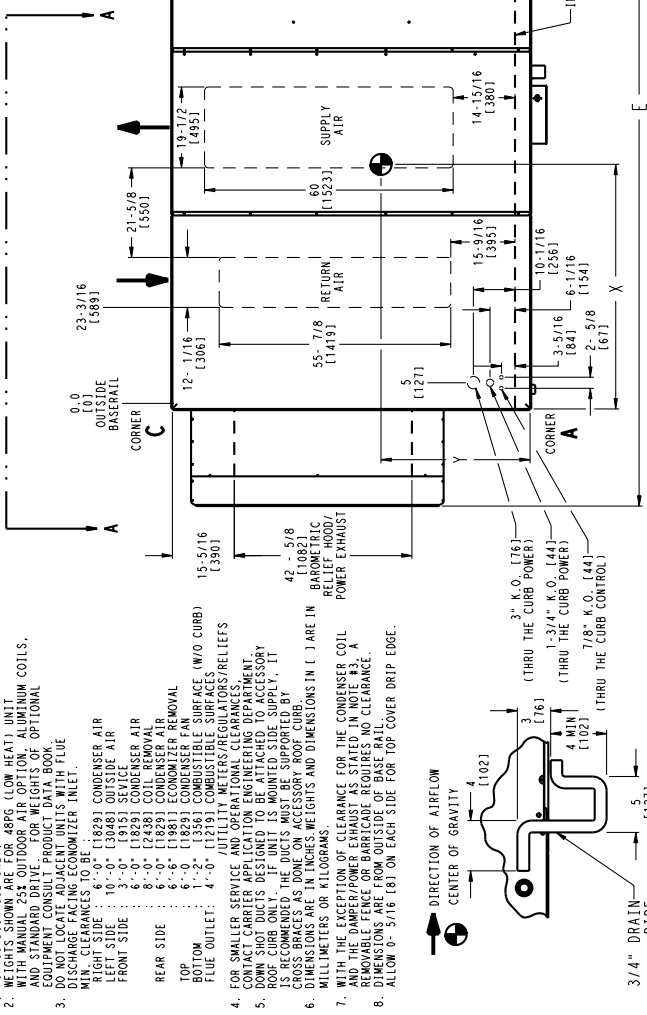
\* DOES NOT INCLUDE ERV ( ENERGY RECOVERY VENTILATOR ) OPTION.



- NOTES:  
1. Add 150 lb (68 kg) for domestic crating.  
2. See label for unit location on roof curb.

**Fig. 3 — Rigging Details**

UNIT SIZE	OPERATING WEIGHT (AS SHOWN)		UNIT HEIGHT		UNIT LENGTH		UNIT LENGTH		UNIT LENGTH		CENTER OF GRAVITY LOCATION		CORNER WEIGHT					
	LB. (KG)	AS SHOWN	IN. (MM)	IN. (MM)	IN. (MM)	IN. (MM)	IN. (MM)	IN. (MM)	IN. (MM)	IN. (MM)	IN. (MM)	X	Y	A	B	C	D	
48PQ20	2480	(1125)	57-3/4	(1467)	172-15/16	(4392)	130-1/16	(3304)	69.6	35.4	29.6	29.6	682.4	783.5	172.1	1542.0		
48PQ24	2588	(1174)	57-3/4	(1467)	172-15/16	(4392)	130-1/16	(3304)	72.5	35.9	29.6	672.1	843.8	175.3	1596.8			
48PQ28	2773	(1258)	69-3/4	(1771)	145-3/4	(3701)	116-7/16	(2951)	67.1	34.1	33.2	711.0	969.2	162.4	1630.3			



- NOTES:
- FOR OUTDOOR USE ONLY.
  - WEIGHTS SHOWN ARE FOR 48PQ (LOW WET) UNIT AND STANDARD DRIVE MOTOR WITH ALUMINUM COILS. EQUIPMENT CONSULT PRODUCT DATA BOOK.
  - DO NOT LOCATE ADJACENT UNITS WITH FLUE DISCHARGING INTO ECONOMIZER INLET.
  - RIGHT SIDE: 6'-0" (1829) CONDENSER AIR LEFT SIDE: 10'-0" (3048) OUTSIDE AIR FRONT SIDE: 3'-0" (915) SERVICE AIR REAR SIDE: 8'-0" (2438) COIL REMOVAL REAR SIDE: 6'-0" (1829) CONDENSER AIR TOP: 6'-6" (1981) ECONOMIZER REMOVAL BOTTOM: 6'-0" (1829) CONDENSER AIR FLUE OUTLET: 4'-0" (1219) COMBUSTIBLE SURFACES/RELIEFS
  - FOR SMALLER SERVICE AND OPERATIONAL CLEARANCES, DOWNSTREAM OF THE UNIT, THE FLUE OUTLET MUST BE ATTACHED TO A ROOF CURB ONLY. IF UNIT IS MOUNTED SIDE SUPPLY, IT IS RECOMMENDED THE DUCTS MUST BE SUPPORTED BY CROSS BRACES AS DONE ON ACCESSORY ROOF CURB.
  - ALL DIMENSIONS ARE IN METERS OR KILOGRAMS.
  - WITH THE EXCEPTION OF CLEARANCE FOR THE CONDENSER COIL RELIEF HOOD, ALL DIMENSIONS ARE FROM OUTSIDE OF BASE RAIL.
  - REMOVABLE FENCE OR BARRICADE REQUIRES NO CLEARANCE.
  - DIMENSIONS ARE FROM OUTSIDE OF BASE RAIL.
  - ALLOW 0'-3/16 (18) ON EACH SIDE FOR TOP COVER DRIP EDGE.

Fig. 4 — Base Unit Dimensions

**Table 1 — Physical Data**

UNIT 48PG	20		24		28	
<b>VOLTAGE</b>	208/230 and 460	575	208/230 and 460	575	208/230 and 460	575
<b>NOMINAL CAPACITY (Tons)</b>	18	18	20	20	25	25
<b>OPERATING WEIGHT (lb)</b> 48 Series (Low Heat) AI/AI*	2480	2480	2588	2588	2773	2773
<b>COMPRESSOR</b>	Fully Hermetic Scroll					
Quantity	2	2	2	2	3	3
Number of Refrigerant Circuits	2	2	2	2	2	2
Oil (ounces) Comp A1, A2, B1	85, NA, 85	85, NA, 85	85, NA, 85	85, NA, 85	85, 85, 85	85, 85, 85
<b>REFRIGERANT TYPE</b>	Puron® Refrigerant (R-410A)					
Expansion Device	TXV	TXV	TXV	TXV	TXV	TXV
Change Type						
Operating Charge (lb)						
Circuit A	25.3	25.3	35.7	35.7	49.3	49.3
Circuit B	25.3	25.3	33.5	33.5	24.3	24.3
<b>REFRIGERANT SUBCOOLER</b>	Heat Exchanger Size					
Expansion Device	B15Hx26x26 TXV	B15Hx26x26 TXV	B15Hx26x26 TXV	B15Hx26x26 TXV	B15Hx26x36 TXV	B15Hx26x36 TXV
<b>CONDENSER COIL</b>	Enhanced Copper Tubes, Aluminum Lanced Fins					
Rows...Fins/inch	2...17	2...17	3...17	3...17	3...17	3...17
Quantity	2	2	3	3	3	3
Length of Tube Sheets (in.)	80.3	80.3	80.3	80.3	80.3	80.3
Width (in.)	60	60	60	60	60	60
Total Face area (sq. ft)	33.46	33.46	33.46	33.46	33.46	33.46
<b>CONDENSER FAN</b>	Propeller					
Nominal Cfm (Total, all fans)	14,000	14,000	21,000	21,000	21,000	21,000
Quantity...Diameter (in.)	4...22	4...22	6...22	6...22	6...22	6...22
Motor Hp...Rpm	1/4...1100	1/4...1100	1/4...1100	1/4...1100	1/4...1100	1/4...1100
Watts input (Total)	1400	1400	2100	2100	2100	2100
<b>EVAPORATOR COIL</b>	Enhanced Copper Tubes, Face Split, Aluminum Double-Wavy Fins					
Rows...Fins/inch	4...15	4...15	4...15	4...15	4...15	4...15
Length of Tube Sheets (in.)	69.4	69.4	69.4	69.4	69.4	69.4
Width (in.)	48	48	48	48	60	60
Total Face area (sq ft)	23.13	23.13	23.13	23.13	28.92	28.92
<b>EVAPORATOR FAN</b>	Centrifugal, Belt Type					
Quantity...Size (in.)	2...15 x 11	2...15 x 11	2...15 x 11	2...15 x 11	2...15 x 11	2...15 x 11
Type Drive	Belt	Belt	Belt	Belt	Belt	Belt
Nominal Cfm	7000	7000	8000	8000	10,000	10,000
Motor Bearing Type	Ball	Ball	Ball	Ball	Ball	Ball
Maximum Allowable Fan Rpm	1400	1400	1400	1400	1400	1400
<b>FURNACE SECTION</b>	Rollout Switch Cutout Temp (F)					
Gas	Vertical	225	225	225	225	225
Thermostat Heat Anticipator Setting		0.136...29	0.136...29	0.136...29	0.136...29	0.136...29
Stage 1 (amps)		Natural	Natural	Natural	Natural	Natural
Stage 2 (amps)		0.98	0.98	0.98	0.98	0.98
Gas Input (Btuh) HIGH HEAT	Stage 1	0.44	0.44	0.44	0.44	0.44
Efficiency (Steady State) %	Stage 2	317,000	317,000	317,000	317,000	317,000
Temperature Rise Range	Vertical	400,000	400,000	400,000	400,000	400,000
Gas Input (Btuh) MEDIUM HEAT		82	82	82	82	82
Efficiency (Steady State) %	Stage 1	25-55	25-55	25-55	25-55	25-55
Temperature Rise Range	Stage 2	281,000	281,000	281,000	281,000	281,000
Gas Input (Btuh) LOW HEAT	Vertical	365,000	365,000	365,000	365,000	365,000
Efficiency (Steady State) %		81	81	81	81	81
Temperature Rise Range	Stage 1	25-55	25-55	25-55	25-55	25-55
Gas Input (Btuh) LOW HEAT	Stage 2	199,000	199,000	199,000	199,000	199,000
Efficiency (Steady State) %	Vertical	250,000	250,000	250,000	250,000	250,000
Temperature Rise Range		82	82	82	82	82
Manifold Pressure		15-45	15-45	15-45	15-45	15-45
Natural Gas (in. wg)	Vertical	3.00	3.00	3.00	3.00	3.00
Natural Gas (in. wg)	Horizontal	2.95	2.95	2.95	2.95	2.95
Gas Valve Quantity		1	1	1	1	1
Gas Valve Pressure Range	(in. wg)	5.5-13.0	5.5-13.0	5.5-13.0	5.5-13.0	5.5-13.0
Min-Max Allowable	(psig)	.235-.469	.235-.469	.235-.469	.235-.469	.235-.469
Field Gas Connection Size (in...FPT)		3/4	3/4	3/4	3/4	3/4
<b>HIGH-PRESSURE SWITCHES (psig)</b>	Cutout					
Reset (Auto)		630 ± 10	630 ± 10	630 ± 10	630 ± 10	630 ± 10
		505 ± 20	505 ± 20	505 ± 20	505 ± 20	505 ± 20
<b>OUTDOOR AIR INLET SCREENS</b>	Quantity...Size (in.)					
		3...20 x 25	3...20 x 25	3...20 x 25	3...20 x 25	3...20 x 25
<b>RETURN-AIR FILTERS</b>	Quantity...Size (in.)					
		9...16 x 25 x 2	9...16 x 25 x 2	9...16 x 25 x 2	9...20 x 25 x 2	9...20 x 25 x 2

LEGEND

TXV — Thermostatic Expansion Valve

\*Aluminum evaporator coil/aluminum condenser coil.

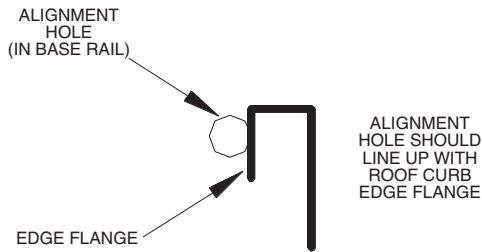
**Table 2 — Fan Motor and Drive Data — Vertical Supply/Return**

48PG	20		24		28	
	208/230 and 460	575	208/230 and 460	575	208/230 and 460	575
<b>LOW RANGE</b>						
Motor Hp	3.7	5	3.7	5	5	5
Motor Nominal Rpm	1750	1750	1750	1750	1750	1750
Maximum Continuous Bhp	4.26	5.75	4.26	5.75	5.75	5.75
Maximum Continuous Watts	3174	4290	3174	4290	4290	4290
Motor Frame Size	56HZ	S184T	56HZ	S184T	S184T	S184T
Motor Shaft Diameter (in.)	7/8	1 1/8	7/8	1 1/8	1 1/8	1 1/8
Fan Rpm Range	685-939	751-954	685-939	751-954	687-873	687-873
Motor Pulley Min. Pitch Diameter (in.)	2.7	3.7	2.7	3.7	3.7	3.7
Motor Pulley Max. Pitch Diameter (in.)	3.7	4.7	3.7	4.7	4.7	4.7
Blower Pulley Pitch Diameter (in.)	6.8	8.6	6.8	8.6	9.4	9.4
Blower Pulley Shaft Diameter (in.)	1 3/16	1 3/16	1 3/16	1 3/16	1 3/16	1 3/16
Blower Pulley Type	Fixed	Fixed	Fixed	Fixed	Fixed	Fixed
Pulley Center Line Distance (in.)	11.293-13.544	9.81-13.055	11.293-13.544	9.81-13.055	9.81-13.055	9.81-13.055
Belt, Quantity...Type...Length (in.)	1...BX38...39.8	1...BX40...41.8	1...BX38...39.8	1...BX40...41.8	1...BX41...42.8	1...BX41...42.8
Speed Change Per Turn — Moveable Pulley (rpm)	42	34	42	34	31	31
Moveable Pulley Maximum Full Turns	6	6	6	6	6	6
Factory Speed Setting (rpm)	812	853	812	853	780	780
<b>MID-LOW RANGE</b>						
Motor Hp	5	5	5	5	5	5
Motor Nominal Rpm	1750	1750	1750	1750	1750	1750
Maximum Continuous Bhp	5.75	5.75	5.75	5.75	5.75	5.75
Maximum Continuous Watts	4290	4290	4290	4290	4290	4290
Motor Frame Size	S184T	S184T	S184T	S184T	S184T	S184T
Motor Shaft Diameter (in.)	1 1/8	1 1/8	1 1/8	1 1/8	1 1/8	1 1/8
Fan Rpm Range	949-1206	949-1206	949-1206	949-1206	805-1007	805-1007
Motor Pulley Min. Pitch Diameter (in.)	3.7	3.7	3.7	3.7	4.8	4.8
Motor Pulley Max. Pitch Diameter (in.)	4.7	4.7	4.7	4.7	6	6
Blower Pulley Pitch Diameter (in.)	6.8	6.8	6.8	6.8	10.4	10.4
Blower Pulley Shaft Diameter (in.)	1 3/16	1 3/16	1 3/16	1 3/16	1 3/16	1 3/16
Blower Pulley Type	Fixed	Fixed	Fixed	Fixed	Fixed	Fixed
Pulley Center Line Distance (in.)	9.81-13.055	9.81-13.055	9.81-13.055	9.81-13.055	9.81-13.055	9.81-13.055
Belt, Quantity...Type...Length (in.)	1...BX38...39.8	1...BX38...39.8	1...BX38...39.8	1...BX38...39.8	1...BX45...46.8	1...BX45...46.8
Speed Change Per Turn — Moveable Pulley (rpm)	43	43	43	43	34	34
Moveable Pulley Maximum Full Turns	6	6	6	6	6	6
Factory Speed Setting (rpm)	1078	1078	1178	1078	906	906
<b>MID-HIGH RANGE</b>						
Motor Hp	7.5	7.5	7.5	7.5	7.5	7.5
Motor Nominal Rpm	1750	1750	1750	1750	1750	1750
Maximum Continuous Bhp	8.63	8.63	8.63	8.63	8.63	8.63
Maximum Continuous Watts	6434	6434	6434	6434	6434	6434
Motor Frame Size	S213T	S213T	S213T	S213T	S213T	S213T
Motor Shaft Diameter (in.)	1 3/8	1 3/8	1 3/8	1 3/8	1 3/8	1 3/8
Fan Rpm Range	941-1176	941-1176	941-1176	941-1176	941-1176	941-1176
Motor Pulley Min. Pitch Diameter (in.)	4.8	4.8	4.8	4.8	4.8	4.8
Motor Pulley Max. Pitch Diameter (in.)	6.0	6.0	6.0	6.0	6.0	6.0
Blower Pulley Pitch Diameter (in.)	8.9	8.9	8.9	8.9	8.9	8.9
Blower Pulley Shaft Diameter (in.)	1 3/16	1 3/16	1 3/16	1 3/16	1 3/16	1 3/16
Blower Pulley Type	Fixed	Fixed	Fixed	Fixed	Fixed	Fixed
Pulley Center Line Distance (in.)	9.025-12.179	9.025-12.179	9.025-12.179	9.025-12.179	9.025-12.179	9.025-12.179
Belt, Quantity...Type...Length (in.)	1...BX42...43.8	1...BX42...43.8	1...BX42...43.8	1...BX42...43.8	1...BX42...43.8	1...BX42...43.8
Speed Change Per Turn — Moveable Pulley (rpm)	39	39	39	39	39	39
Moveable Pulley Maximum Full Turns	6	6	6	6	6	6
Factory Speed Setting (rpm)	1059	1059	1059	1059	1059	1059
<b>HIGH RANGE</b>						
Motor Hp	10	10	10	10	10	10
Motor Nominal Rpm	1750	1750	1750	1750	1750	1750
Maximum Continuous Bhp	11.50	11.50	11.50	11.50	11.50	11.50
Maximum Continuous Watts	8579	8579	8579	8579	8579	8579
Motor Frame Size	S215T	S215T	S215T	S215T	S215T	S215T
Motor Shaft Diameter (in.)	1 3/8	1 3/8	1 3/8	1 3/8	1 3/8	1 3/8
Fan Rpm Range	1014-1297	1014-1297	1014-1297	1014-1297	1014-1297	1014-1297
Motor Pulley Min. Pitch Diameter (in.)	4.3	4.3	4.3	4.3	4.3	4.3
Motor Pulley Max. Pitch Diameter (in.)	5.5	5.5	5.5	5.5	5.5	5.5
Blower Pulley Pitch Diameter (in.)	7.4	7.4	7.4	7.4	7.4	7.4
Blower Pulley Shaft Diameter (in.)	1 3/16	1 3/16	1 3/16	1 3/16	1 3/16	1 3/16
Blower Pulley Type	Fixed	Fixed	Fixed	Fixed	Fixed	Fixed
Pulley Center Line Distance (in.)	9.025-12.179	9.025-12.179	9.025-12.179	9.025-12.179	9.025-12.179	9.025-12.179
Belt, Quantity...Type...Length (in.)	2...BX38...39.8	2...BX38...39.8	2...BX38...39.8	2...BX38...39.8	2...BX38...39.8	2...BX38...39.8
Speed Change Per Turn — Moveable Pulley (rpm)	47	47	47	47	47	47
Moveable Pulley Maximum Full Turns	6	6	6	6	6	6
Factory Speed Setting (rpm)	1156	1156	1156	1156	1156	1156

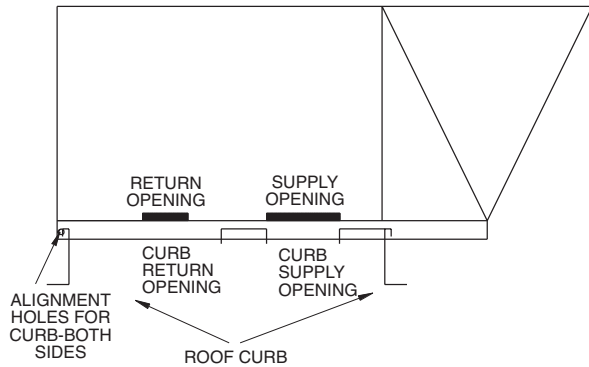
Table 3 — Fan Motor and Drive Data — Horizontal Supply/Return

48PG	20		24		28	
	208/230 and 460	575	208/230 and 460	575	208/230 and 460	575
<b>LOW RANGE</b>						
Motor Hp	—	—	—	—	5	5
Motor Nominal Rpm	—	—	—	—	1750	1750
Maximum Continuous Bhp	—	—	—	—	5.75	5.75
Maximum Continuous Watts	—	—	—	—	4290	4290
Motor Frame Size	—	—	—	—	S184T	S184T
Motor Shaft Diameter (in.)	—	—	—	—	1 <sup>1</sup> / <sub>8</sub>	1 <sup>1</sup> / <sub>8</sub>
Fan Rpm Range	—	—	—	—	687-873	687-873
Motor Pulley Min. Pitch Diameter (in.)	—	—	—	—	3.7	3.7
Motor Pulley Max. Pitch Diameter (in.)	—	—	—	—	4.7	4.7
Blower Pulley Pitch Diameter (in.)	—	—	—	—	9.4	9.4
Blower Pulley Shaft Diameter (in.)	—	—	—	—	1 <sup>3</sup> / <sub>16</sub>	1 <sup>3</sup> / <sub>16</sub>
Blower Pulley Type	—	—	—	—	Fixed	Fixed
Pulley Center Line Distance (in.)	—	—	—	—	9.81-13.055	9.81-13.055
Belt, Quantity...Type...Length (in.)	—	—	—	—	1...BX41...42.8	1...BX41...42.8
Speed Change Per Turn — Moveable Pulley (rpm)	—	—	—	—	31	31
Moveable Pulley Maximum Full Turns	—	—	—	—	6	6
Factory Speed Setting (rpm)	—	—	—	—	780	780
<b>MID-LOW RANGE</b>						
Motor Hp	3.7	5	3.7	5	5	5
Motor Nominal Rpm	1750	1750	1750	1750	1750	1750
Maximum Continuous Bhp	4.26	5.75	4.26	5.75	5.75	5.75
Maximum Continuous Watts	3174	4290	3174	4290	4290	4290
Motor Frame Size	56HZ	S184T	56HZ	S184T	S184T	S184T
Motor Shaft Diameter (in.)	7 <sup>7</sup> / <sub>8</sub>	1 <sup>1</sup> / <sub>8</sub>	7 <sup>7</sup> / <sub>8</sub>	1 <sup>1</sup> / <sub>8</sub>	1 <sup>1</sup> / <sub>8</sub>	1 <sup>1</sup> / <sub>8</sub>
Fan Rpm Range	896-1227	873-1108	896-1227	873-1108	805-1007	805-1007
Motor Pulley Min. Pitch Diameter (in.)	2.7	3.7	2.7	3.7	4.8	4.8
Motor Pulley Max. Pitch Diameter (in.)	3.7	4.7	3.7	4.7	6.0	6.0
Blower Pulley Pitch Diameter (in.)	5.2	7.4	5.2	7.4	10.4	10.4
Blower Pulley Shaft Diameter (in.)	1 <sup>3</sup> / <sub>16</sub>	1 <sup>3</sup> / <sub>16</sub>	1 <sup>3</sup> / <sub>16</sub>	1 <sup>3</sup> / <sub>16</sub>	1 <sup>3</sup> / <sub>16</sub>	1 <sup>3</sup> / <sub>16</sub>
Blower Pulley Type	Fixed	Fixed	Fixed	Fixed	Fixed	Fixed
Pulley Center Line Distance (in.)	11.293-13.544	9.81-13.055	11.293-13.544	9.81-13.055	9.81-13.055	9.81-13.055
Belt, Quantity...Type...Length (in.)	1...BX35...36.8	1...BX38...39.8	1...BX35...36.8	1...BX38...39.8	1...BX45...46.8	1...BX45...46.8
Speed Change Per Turn — Moveable Pulley (rpm)	55	39	55	39	34	34
Moveable Pulley Maximum Full Turns	6	6	6	6	6	6
Factory Speed Setting (rpm)	1062	991	1062	991	906	906
<b>MID-HIGH RANGE</b>						
Motor Hp	5	5	5	5	7.5	7.5
Motor Nominal Rpm	1750	1750	1750	1750	1750	1750
Maximum Continuous Bhp	5.75	5.75	5.75	5.75	8.63	8.63
Maximum Continuous Watts	4290	4290	4290	4290	6434	6434
Motor Frame Size	S184T	S184T	S184T	S184T	S213T	S213T
Motor Shaft Diameter (in.)	1 <sup>1</sup> / <sub>8</sub>	1 <sup>1</sup> / <sub>8</sub>	1 <sup>1</sup> / <sub>8</sub>	1 <sup>1</sup> / <sub>8</sub>	1 <sup>3</sup> / <sub>8</sub>	1 <sup>3</sup> / <sub>8</sub>
Fan Rpm Range	1113-1414	1113-1414	1113-1414	1113-1414	941-1176	941-1176
Motor Pulley Min. Pitch Diameter (in.)	3.7	3.7	3.7	3.7	4.8	4.8
Motor Pulley Max. Pitch Diameter (in.)	4.7	4.7	4.7	4.7	6.0	6.0
Blower Pulley Pitch Diameter (in.)	5.8	5.8	5.8	5.8	8.9	8.9
Blower Pulley Shaft Diameter (in.)	1 <sup>3</sup> / <sub>16</sub>	1 <sup>3</sup> / <sub>16</sub>	1 <sup>3</sup> / <sub>16</sub>	1 <sup>3</sup> / <sub>16</sub>	1 <sup>3</sup> / <sub>16</sub>	1 <sup>3</sup> / <sub>16</sub>
Blower Pulley Type	Fixed	Fixed	Fixed	Fixed	Fixed	Fixed
Pulley Center Line Distance (in.)	9.81-13.055	9.81-13.055	9.81-13.055	9.81-13.055	9.025-12.179	9.025-12.179
Belt, Quantity...Type...Length (in.)	1...BX35...36.8	1...BX35...36.8	1...BX35...36.8	1...BX35...36.8	1...BX42...43.8	1...BX42...43.8
Speed Change Per Turn — Moveable Pulley (rpm)	50	50	50	50	39	39
Moveable Pulley Maximum Full Turns	6	6	6	6	6	6
Factory Speed Setting (rpm)	1264	1264	1264	1264	1059	1059
<b>HIGH RANGE</b>						
Motor Hp	7.5	7.5	7.5	7.5	10	10
Motor Nominal Rpm	1750	1750	1750	1750	1750	1750
Maximum Continuous Bhp	8.63	8.63	8.63	8.63	11.50	11.50
Maximum Continuous Watts	6434	6434	6434	6434	8579	8579
Motor Frame Size	S213T	S213T	S213T	S213T	S215T	S215T
Motor Shaft Diameter (in.)	1 <sup>3</sup> / <sub>8</sub>	1 <sup>3</sup> / <sub>8</sub>	1 <sup>3</sup> / <sub>8</sub>	1 <sup>3</sup> / <sub>8</sub>	1 <sup>3</sup> / <sub>8</sub>	1 <sup>3</sup> / <sub>8</sub>
Fan Rpm Range	1096-1339	1096-1339	1096-1339	1096-1339	1014-1297	1014-1297
Motor Pulley Min. Pitch Diameter (in.)	5.4	5.4	5.4	5.4	4.3	4.3
Motor Pulley Max. Pitch Diameter (in.)	6.6	6.6	6.6	6.6	5.5	5.5
Blower Pulley Pitch Diameter (in.)	8.6	8.6	8.6	8.6	7.4	7.4
Blower Pulley Shaft Diameter (in.)	1 <sup>3</sup> / <sub>16</sub>	1 <sup>3</sup> / <sub>16</sub>	1 <sup>3</sup> / <sub>16</sub>	1 <sup>3</sup> / <sub>16</sub>	1 <sup>3</sup> / <sub>16</sub>	1 <sup>3</sup> / <sub>16</sub>
Blower Pulley Type	Fixed	Fixed	Fixed	Fixed	Fixed	Fixed
Pulley Center Line Distance (in.)	9.025-12.179	9.025-12.179	9.025-12.179	9.025-12.179	9.025-12.179	9.025-12.179
Belt, Quantity...Type...Length (in.)	1...BX42...43.8	1...BX42...43.8	1...BX42...43.8	1...BX42...43.8	1...BX38...39.8	1...BX38...39.8
Speed Change Per Turn — Moveable Pulley (rpm)	41	41	41	41	47	47
Moveable Pulley Maximum Full Turns	6	6	6	6	6	6
Factory Speed Setting (rpm)	1218	1218	1218	1218	1156	1156





**Fig. 5 — Alignment Hole Details**



**Fig. 6 — Alignment Hole Location**

**Step 4 — Field Fabricate Ductwork** — On vertical units, secure all ducts to roof curb and building structure. *Do not connect ductwork to unit.* For horizontal applications, field-supplied flanges should be attached to horizontal discharge openings and all ductwork secured to the flanges. Insulate and weatherproof all external ductwork, joints, and roof openings with counter flashing and mastic in accordance with applicable codes.

Ducts passing through an unconditioned space must be insulated and covered with a vapor barrier.

If a plenum return is used on a vertical unit, the return should be ducted through the roof deck to comply with applicable fire codes.

A minimum clearance is not required around ductwork. Cabinet return-air static shall not exceed  $-0.35$  in. wg with economizer or  $0.45$  in. wg without economizer.

These units are designed for a minimum continuous return-air temperature in heating of  $50$  F (dry bulb), or an intermittent operation down to  $45$  F (dry bulb), such as when used with a night set-back thermostat.

To operate at lower return-air temperatures, a field-supplied outdoor-air temperature control must be used to initiate both stages of heat when the temperature is below  $45$  F. Indoor comfort may be compromised when these lower air temperatures are used with insufficient heating temperature rise.

**Step 5 — Make Unit Duct Connections**

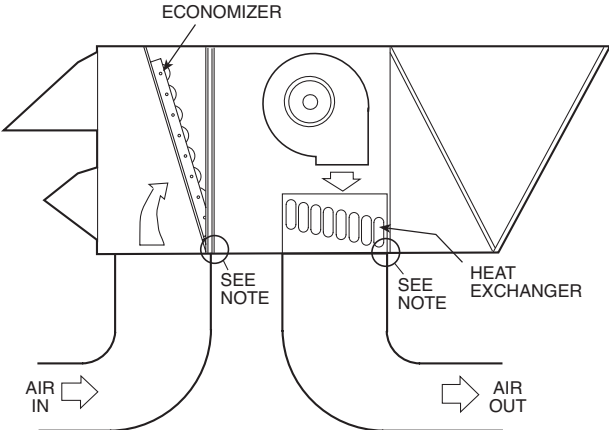
**VERTICAL CONFIGURATION** — Unit is shipped for vertical supply and return duct connections. Ductwork openings are shown in Fig. 1 and 4. Duct connections for vertical configuration are shown in Fig. 7. Field-fabricated concentric ductwork may be connected as shown in Fig. 8 and 9. The unit is designed to attach the ductwork to the roof curb. Do not attach duct directly to the unit.

**⚠ WARNING**

For vertical supply and return units, tools or parts could drop into ductwork and cause an injury. Install a 90 degree turn in the return ductwork between the unit and the conditioned space. If a 90 degree elbow cannot be installed, then a grille of sufficient strength and density should be installed to prevent objects from falling into the conditioned space.

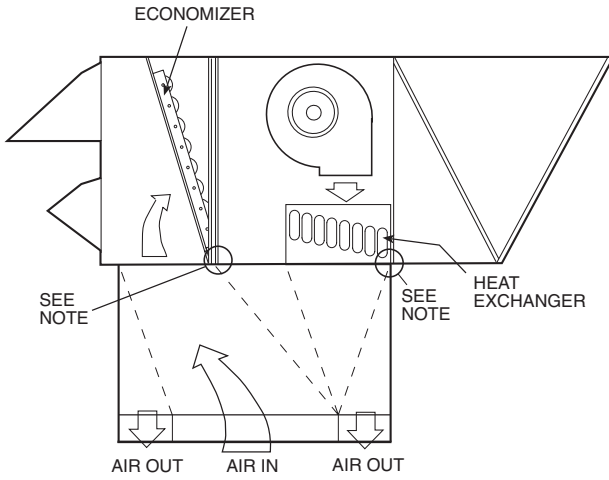
**HORIZONTAL APPLICATIONS** — Horizontal units are shipped with outer panels that allow for side by side horizontal duct connections. If specified during ordering, the unit will be shipped with the vertical duct openings blocked off from the factory, ready for side supply installation. If the horizontal supply/return option was not specified at time of ordering the unit, a field-installed accessory kit is required to convert the vertical unit into a horizontal supply configuration.

Installation of the duct block-off covers should be completed prior to placing the unit unless sufficient side clearance is available. A minimum of  $66$  in. is required between the unit and any obstruction to install the duct block-off covers. Side supply duct dimensions and locations are shown on Fig. 4. Install ductwork to horizontal duct flange connections on side of unit.



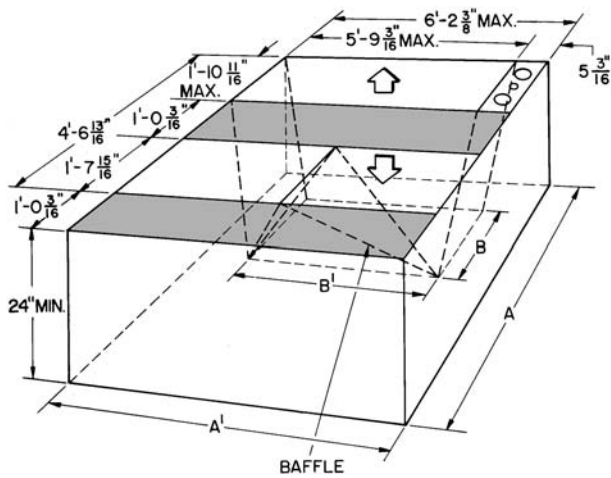
NOTE: Do not drill in this area; damage to basepan may result in water leak.

**Fig. 7 — Air Distribution — Vertical Supply/Return**



NOTE: Do not drill in this area; damage to basepan may result in water leak.

**Fig. 8 — Air Distribution — Concentric Duct**



NOTE: Dimensions A, A', B, and B' are obtained from field-supplied ceiling diffuser.

Shaded areas indicate block-off pans.

**Fig. 9 — Concentric Duct Details**

### Step 6 — Install Flue Hood and Inlet Hood —

Flue hood (smaller hood), inlet hood (larger hood), and screens are shipped inside the unit in the fan section. To install, remove the heat panel. The flue hood is attached to the heat section panel from the outside using the screws provided. See Fig. 10.

The inlet hood is installed by inserting the hood through the back of the heat panel. Attach the hood by inserting the screws provided through the clearance holes in the heat panel and into the intake hood.

Install the screens into both hoods using the screws and retaining nuts provided with the unit.

Attach the cover of the observation hole on the intake hood and then replace the heat panel onto the unit to complete the installation.

NOTE: When properly installed, the flue hood will line up with the combustion fan housing. See Fig. 11.

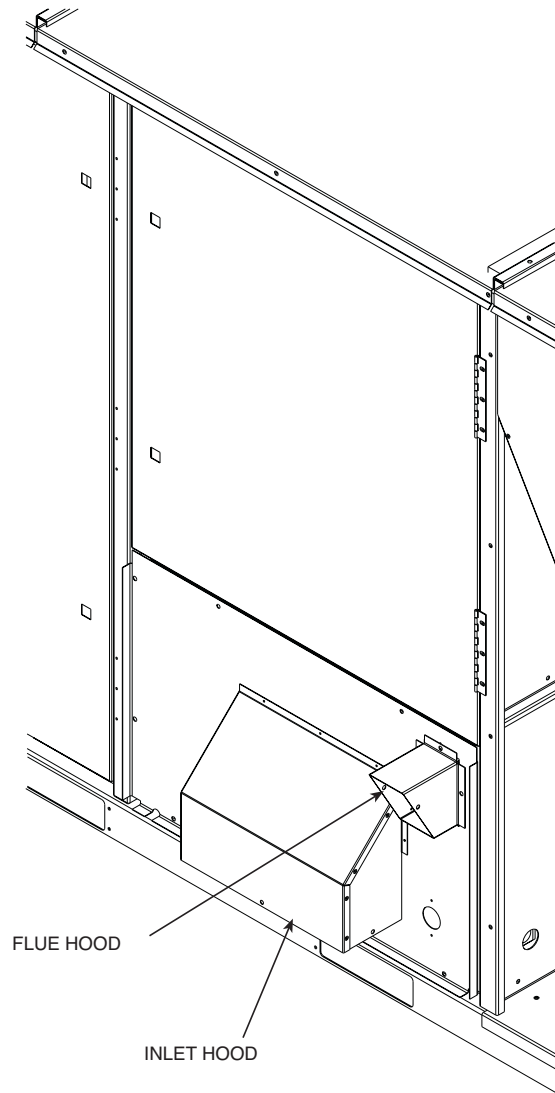
**Step 7 — Trap Condensate Drain —** See Fig. 12 for drain location. One 3/4-in. half coupling is provided outside unit evaporator section for condensate drain connection. A trap at least 4-in. deep must be used. See Fig. 13.

All units must have an external trap for condensate drainage. Install a trap at least 4 in. deep and protect against freeze-up. If drain line is installed downstream from the external trap, pitch the line away from the unit at 1 in. per 10 ft of run. Do not use a pipe size smaller than the unit connection.

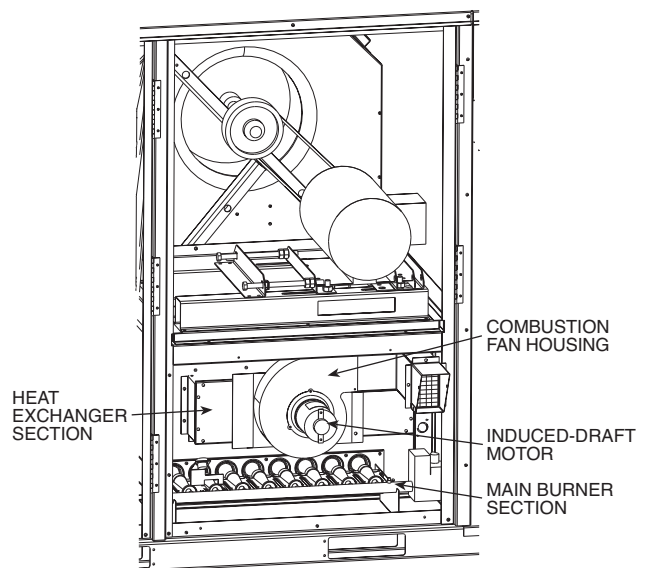
**Step 8 — Install Gas Piping —** Unit is equipped for use with natural gas. Refer to local building codes, or in the absence of local codes, to ANSI Z223.1-latest year and addendum Z223.1A-latest year entitled NFGC. In Canada, installation must be in accordance with the CAN1.B149.1 and CAN1.B149.2 installation codes for gas burning appliances.

Support gas piping. For example, a 3/4-in. gas pipe must have one field-fabricated support beam every 8 ft. Therefore, an 18-ft long gas pipe would have a minimum of 3 support beams.

Install field-supplied manual gas shutoff valve with a 1/8-in. NPT pressure tap for test gage connection at unit. The pressure tap is located on the gas manifold, adjacent to the gas valve. Field gas piping must include sediment trap and union. See Fig. 14.



**Fig. 10 — Flue and Inlet Hood Locations**



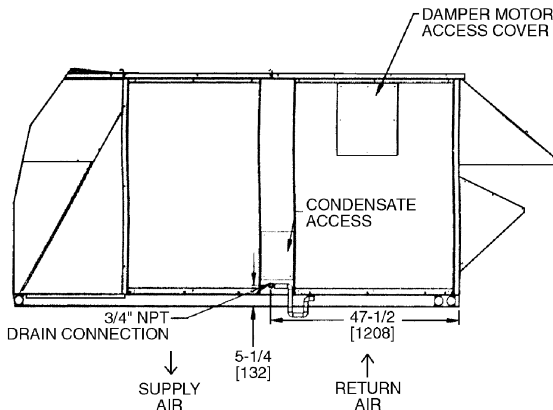
**Fig. 11 — Combustion Fan Housing Location**

**⚠ WARNING**

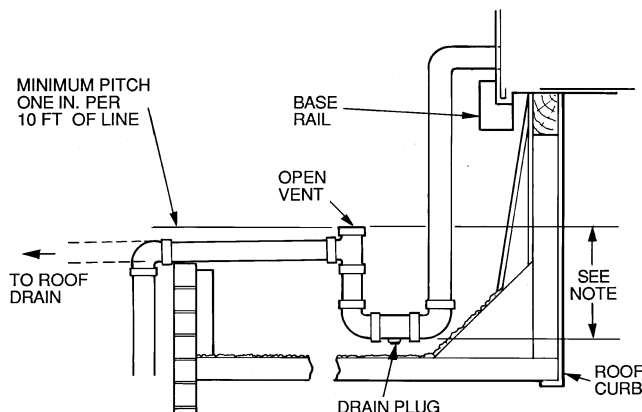
Do not pressure test gas supply while connected to unit. Always disconnect union before servicing.

**IMPORTANT:** Natural gas pressure at unit gas connection must not be less than 5.5 in. wg or greater than 13.0 in. wg.

Size gas-supply piping for 0.5-in. wg maximum pressure drop. Do not use supply pipe smaller than unit gas connection.

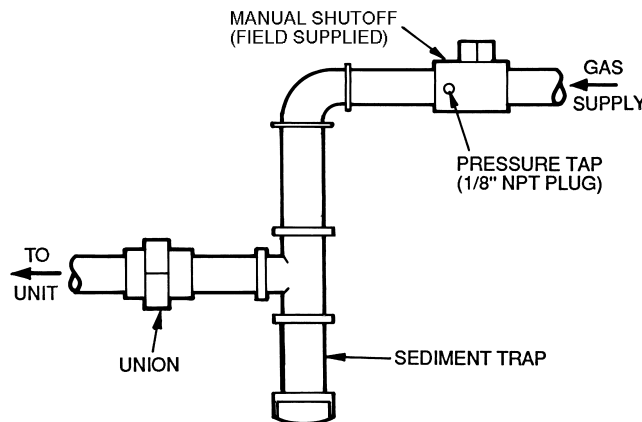


**Fig. 12 — Condensate Drain Details**



NOTE: Trap should be deep enough to offset maximum unit static difference. A 4-in. trap is recommended.

**Fig. 13 — Condensate Drain Piping Details**



**Fig. 14 — Field Gas Piping**

**Step 9 — Make Electrical Connections**

**FIELD POWER SUPPLY** — Unit is factory wired for voltage shown on unit nameplate. Be sure to check for correct voltage.

When installing units, provide disconnect per NEC (National Electrical Code) of adequate size (MOCP [Maximum Over-current protection] of unit is on the informative plate). See Tables 4A and 4B. All field wiring must comply with NEC and local codes. Size wire based on MCA (Minimum Circuit Amps) on the unit informative plate. See Fig. 15 for power wiring connection to the unit power terminal block and equipment ground.

Route power and ground lines through control box end panel or unit basepan (see Fig. 4) to connections as shown on unit wiring diagram and Fig. 15.

**⚠ CAUTION**

The correct power phasing is critical to the operation of the scroll compressors. An incorrect phasing will result in compressor shutdown on thermal overload and possible damage to compressor. Should this occur, power phase correction must be made to the incoming power.

**⚠ WARNING**

Unit cabinet must have an uninterrupted, unbroken electrical ground to minimize the possibility of personal injury if an electrical fault should occur. This ground may consist of electrical wire connected to unit ground lug in control compartment, or conduit approved for electrical ground when installed in accordance with NEC, ANSI/NFPA (American National Standards Institute/National Fire Protection Association), latest edition, and local electrical codes. *Do not use gas piping as an electrical ground.* Failure to follow this warning could result in the installer being liable for personal injury of others.

Field wiring must conform to temperature limitations for type "T" wire. All field wiring must comply with NEC and local requirements.

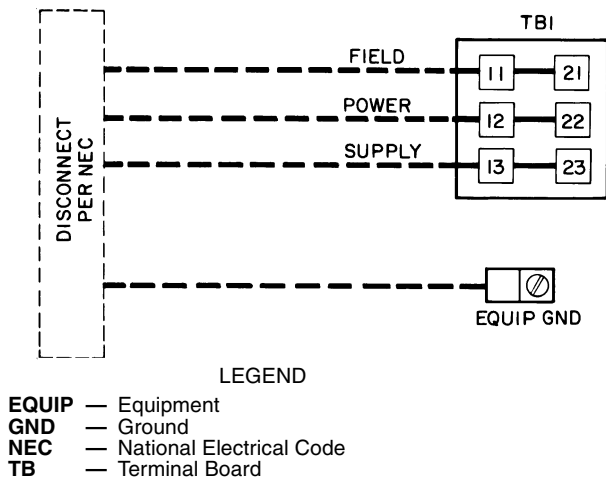
Operating voltage to compressor must be within voltage range indicated on unit nameplate. On 3-phase units, voltages between phases must be balanced within 2%.

Unit failure as a result of operation on improper line voltage or excessive phase imbalance constitutes abuse and may cause damage to electrical components.

**FIELD CONTROL WIRING** — Unit can be controlled with either a Carrier-approved accessory thermostat. Install thermostat according to the installation instructions included with accessory. Locate thermostat assembly on a solid interior wall in the conditioned space to sense average temperature.

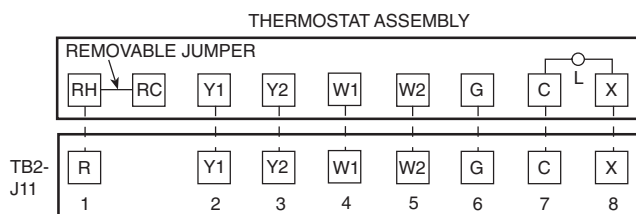
Route thermostat cable or equivalent single leads of colored wire from subbase terminals through conduit into unit to low-voltage connections as shown on unit label wiring diagram and in Fig. 16.

NOTE: For wire runs up to 50 ft, use no. 18 AWG (American Wire Gage) insulated wire (35 C minimum). For 50 to 75 ft, use no. 16 AWG insulated wire (35 C minimum). For over 75 ft, use no. 14 AWG insulated wire (35 C Minimum). All wire larger than no. 18 AWG cannot be directly connected at the thermostat and will require a junction box and splice at the thermostat.



NOTE: The maximum wire size for TB1 is 2/0.

**Fig. 15 — Field Power Wiring Connections**



**Fig. 16 — Field Control Thermostat Wiring**

Set heat anticipator settings as follows:

VOLTAGE	STAGE 1 (W1) ON	STAGE 1 AND 2 (W1 AND W2) ON
All	0.98	0.44

Settings may be changed slightly to provide a greater degree of comfort for a particular installation.

**Step 10 — Install Outdoor Air Hood —** Perform the following procedure to install the outdoor-air hood on units equipped with an economizer, two-position damper, or manual outdoor air damper:

1. Remove blank panel from return end of unit (hood section). Save the screws. See Fig. 17 for shipping location of components.
2. Hood sides are fastened to sides of outdoor air opening. Remove the hood sides and save the screws (3 each side).
3. Remove the bracket holding the bottom half of the hood in the shipping position. Remove the hood bottom half and filters (or manual dampers on units so equipped) from outdoor section.

NOTE: On units without economizers, the components are attached to the unit basepan. To access the components, remove the panel below the outdoor air intake section.

4. Remove inner filter track from shipping position in outdoor section. Position inner filter track so the track is

facing outward from the unit. Install the filter track with 4 screws provided.

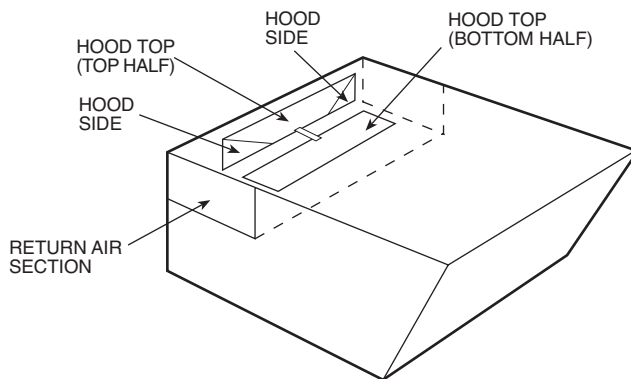
5. Apply seal strip (provided) to back flange of both hood sides where hood side connects to the unit back panel. See Fig. 18.
6. Apply seal strip (provided) to top flange of both hood sides where hood sides connect to the hood top panels. See Fig. 18.
7. Install hood sides to the back panels using the screws from Step 2. The sloped flanges point outward. The drip edges of the side panels should face outward as well. The filter guides to the hood sides. The flanges of the filter guides should face inward to hold the filters in place. See Fig. 18.
8. Apply seal strip along the entire length of the bottom flange of the hood top. See Fig. 18.
9. Install the bottom part of the hood top using 4 screws provided. See Fig. 18.
10. Remove the packaging from filters (3) and install into the filter tracks. Slide the filters to the sides then place the last filter into the center of the filter track.

NOTE: For units with manual dampers, replace the end filters with the manual dampers. Install the filter in the center between the manual dampers.

11. Install the filter retainer track along the bottom edge of the outdoor air hood using 4 screws provided. See Fig. 18.
12. Install top section of the outdoor air hood using 9 screws provided. See Fig. 18. See Fig. 19 for a picture of the assembled outdoor air hood.

NOTE: For filter removal, remove the four screws holding the filter retainer. The filters can then be removed, cleaned, or replaced. Install the filters by reversing the procedure.

**MANUAL DAMPER ASSEMBLY —** For units equipped with manual dampers, the assembly process is similar to the outdoor air hood for units with economizers. There are two slide dampers shipped with the unit to allow for manual setting of the outside air volume. When assembling the hood, place one of the manual slide dampers in each of the end positions and the remaining filter in the center position. The manual dampers can then be moved to the appropriate position and then locked into place using the screws mounted in the adjustment slots. See Fig. 20.



**Fig. 17 — Outdoor-Air Hood Component Shipping Location**

**Table 4A — Electrical Data (Units Without Optional Powered Convenience Outlet)**

UNIT SIZE 48HG	NOMINAL VOLTAGE (3 Ph, 60 Hz)	VOLTAGE RANGE		COMPRESSOR						OFM		IFM		POWER EXHAUST		COMBUSTION FAN MOTOR	POWER SUPPLY*		POWER SUPPLY UNITS WITH OPTIONAL HACR BREAKER		DISCONNECT SIZE		
				No. 1		No. 2		No. 3															
		Min	Max	RLA	LRA	RLA	LRA	RLA	LRA	Qty	Hp	FLA (ea)	Hp	FLA	Qty	Hp	FLA (ea)	FLA	MCA	MOCP	MCA	MOCP	FLA
20	208/230	187	253	28.2	208	28.2	208	—	—	4	0.25	1.5	3.7	10.6/ 9.6	—	—	—	0.5	80/ 79	100/100	80/ 80	100/100	84/ 83
													5	16.7/15.2	2	1	5.9		92/ 91	100/100	92/ 92	100/100	98/ 96
													7.5	24.2/22	2	1	5.9		86/ 85	100/100	86/ 86	100/100	91/ 89
													10	30.8/28	2	1	5.9		98/ 96	100/100	98/ 98	100/100	105/103
															2	1	5.9		94/ 91	100/100	94/ 94	100/100	100/ 97
	460	414	506	15.4	104	15.4	104	—	—	4	0.25	0.7	3.7	4.8	—	—	—	0.3	42	50	42	50	44
													5	7.6	2	1	3.1		48	60	48	60	51
													7.5	11	2	1	3.1		45	60	45	60	47
													10	14	2	1	3.1		51	60	51	60	55
															2	1	3.1		48	60	48	60	51
	575	518	633	12.8	83	12.8	83	—	—	4	0.25	0.7	5	6.1	—	—	—	0.24	38	50	38	50	40
													7.5	9	2	1	2.4		43	50	43	50	45
10													11	2	1	2.4	41		50	41	50	43	
														2	1	2.4	45		50	45	50	49	
														2	1	2.4	43		50	43	50	45	
24	208/230	187	253	32.1	240	32.1	240	—	—	6	0.25	1.5	3.7	10.6/ 9.6	—	—	—	0.5	92/ 91	100/100	92/ 92	100/100	96/ 95
													5	16.7/15.2	2	1	5.9		104/103	125/125	104/104	125/125	110/109
													7.5	24.2/22	2	1	5.9		98/ 96	100/100	98/ 98	100/100	103/102
													10	30.8/28	2	1	5.9		110/108	125/125	110/110	125/125	117/115
															2	1	5.9		105/103	125/125	105/105	125/125	112/109
	460	414	506	15.4	110	15.4	110	—	—	6	0.25	0.7	3.7	4.8	—	—	—	0.3	44	50	44	50	46
													5	7.6	2	1	3.1		50	60	50	60	53
													7.5	11	2	1	3.1		46	60	46	60	49
													10	14	2	1	3.1		53	60	53	60	56
															2	1	3.1		50	60	50	60	53
	575	518	633	12.8	88	12.8	88	—	—	6	0.25	0.7	5	6.1	—	—	—	0.24	39	50	39	50	41
													7.5	9	2	1	2.4		44	50	44	50	47
10													11	2	1	2.4	42		50	42	50	45	
														2	1	2.4	47		50	47	50	50	
														2	1	2.4	44		50	44	50	47	
28	208/230	187	253	28.2	208	28.2	208	28.2	208	6	0.25	1.5	5	16.7/15.2	—	—	—	0.5	117/116	125/125	117/117	125/125	127/125
													7.5	24.2/22	2	1	5.9		129/128	150/150	129/129	150/150	140/139
													10	30.8/28	2	1	5.9		125/123	150/150	125/125	150/150	135/133
															2	1	5.9		137/134	150/150	137/137	150/150	149/147
	460	414	506	15.4	104	15.4	104	15.4	104	6	0.25	0.7	5	7.6	—	—	—	0.3	62	70	62	70	67
													7.5	11	2	1	3.1		68	80	68	80	74
													10	14	2	1	3.1		65	80	65	80	71
															2	1	3.1		71	80	71	80	78
	575	518	633	12.8	83	12.8	83	12.8	83	6	0.25	0.7	5	6.1	—	—	—	0.24	68	80	68	80	74
													7.5	9	2	1	2.4		74	80	74	80	81
													10	11	2	1	2.4		52	60	52	60	56
															2	1	2.4		57	60	57	60	62
		2	1	2.4	55	60	55	60	59														
		2	1	2.4	60	60	60	60	65														
		2	1	2.4	57	60	57	60	62														
		2	1	2.4	62	70	62	70	67														

See Legend and Notes on page 15.

**Table 4B — Electrical Data (Units With Optional Powered Convenience Outlet)**

UNIT SIZE 48HG	NOMINAL VOLTAGE (3 Ph, 60 Hz)	VOLTAGE RANGE		COMPRESSOR						OFM			IFM		POWER EXHAUST			COMBUSTION FAN MOTOR	POWER SUPPLY*		POWER SUPPLY UNITS WITH OPTIONAL HACR BREAKER		DISCONNECT SIZE
				No. 1		No. 2		No. 3															
		Min	Max	RLA	LRA	RLA	LRA	RLA	LRA	Qty	Hp	FLA (ea)	Hp	FLA	Qty	Hp	FLA (ea)	FLA	MCA	MOCP	MCA	MOCP	FLA
20	208/230	187	253	28.2	208	28.2	208	—	—	4	0.25	1.5	3.7	10.6/ 9.6	—	—	—	0.5	85/ 84	100/100	85/ 85	100/100	90/ 89
													2	1	5.9	97/ 96	100/100		97/ 97	100/100	103/102		
													5	16.7/15.2	—	—	—		91/ 90	100/100	91/ 91	100/100	97/ 95
													2	1	5.9	103/101	125/125		103/103	125/125	110/109		
	7.5	24.2/22	—	—	—	99/ 96	100/100	99/ 99	100/100	105/103													
	2	1	5.9	110/108	125/125	110/110	125/125	119/116															
	10	30.8/28	—	—	—	106/102	125/125	106/106	125/125	113/110													
	2	1	5.9	118/114	125/125	118/118	125/125	127/123															
	460	414	506	15.4	104	15.4	104	—	—	4	0.25	0.7	3.7	4.8	—	—	—	0.3	45	60	45	60	48
													2	1	3.1	51	60		51	60	55		
													5	7.6	—	—	—		48	60	48	60	51
													2	1	3.1	54	60		54	60	58		
7.5	11	—	—	—	51	60	51	60	55														
2	1	3.1	58	60	58	60	62																
10	14	—	—	—	54	60	54	60	58														
2	1	3.1	61	70	61	70	65																
575	518	633	12.8	83	12.8	83	—	—	4	0.25	0.7	5	6.1	—	—	—	0.24	41	50	41	50	43	
												2	1	2.4	46	50		46	50	49			
												7.5	9	—	—	—		44	50	44	50	46	
												2	1	2.4	48	60		48	60	52			
10	11	—	—	—	46	50	46	50	49														
2	1	2.4	50	60	50	60	54																
24	208/230	187	253	32.1	240	32.1	240	—	—	6	0.25	1.5	3.7	10.6/ 9.6	—	—	—	0.5	97/ 96	100/100	97/ 97	100/100	102/101
													2	1	5.9	109/108	125/125		109/109	125/125	116/115		
													5	16.7/15.2	—	—	—		103/101	125/125	103/103	125/125	109/107
													2	1	5.9	115/113	125/125		115/115	125/125	123/121		
	7.5	24.2/22	—	—	—	110/108	125/125	110/110	125/125	118/115													
	2	1	5.9	122/120	150/150	122/122	150/150	131/129															
	10	30.8/28	—	—	—	117/114	125/125	117/117	125/125	125/122													
	2	1	5.9	129/126	150/150	129/129	150/150	139/136															
	460	414	506	15.4	110	15.4	110	—	—	6	0.25	0.7	3.7	4.8	—	—	—	0.3	47	60	47	60	49
													2	1	3.1	53	60		53	60	56		
													5	7.6	—	—	—		49	60	49	60	52
													2	1	3.1	56	60		56	60	60		
7.5	11	—	—	—	53	60	53	60	56														
2	1	3.1	59	60	59	60	63																
10	14	—	—	—	56	60	56	60	60														
2	1	3.1	62	70	62	70	67																
575	518	633	12.8	88	12.8	88	—	—	6	0.25	0.7	5	6.1	—	—	—	0.24	42	50	42	50	45	
												2	1	2.4	47	50		47	50	50			
												7.5	9	—	—	—		45	50	45	50	48	
												2	1	2.4	50	60		50	60	54			
10	11	—	—	—	47	50	47	50	50														
2	1	2.4	52	60	52	60	56																
28	208/230	187	253	28.2	208	28.2	208	28.2	208	6	0.25	1.5	5	16.7/15.2	—	—	—	0.5	122/121	150/125	122/122	150/150	133/131
													2	1	5.9	134/133	150/150		134/134	150/150	146/144		
													7.5	24.2/22	—	—	—		130/128	150/150	130/130	150/150	141/139
													2	1	5.9	142/139	150/150		142/142	150/150	155/152		
	10	30.8/28	—	—	—	137/134	150/150	137/137	150/150	149/146													
	2	1	5.9	149/145	175/150	149/149	175/175	162/159															
	460	414	506	15.4	104	15.4	104	15.4	104	6	0.25	0.7	5	7.6	—	—	—	0.3	65	80	65	80	70
													2	1	3.1	71	80		71	80	77		
													7.5	11	—	—	—		68	80	68	80	74
													2	1	3.1	74	80		74	80	81		
	10	14	—	—	—	71	80	71	80	78													
	2	1	3.1	77	90	77	90	85															
575	518	633	12.8	83	12.8	83	12.8	83	6	0.25	0.7	5	6.1	—	—	—	0.24	55	60	55	60	59	
												2	1	2.4	60	60		60	60	65			
												7.5	9	—	—	—		58	60	58	60	63	
												2	1	2.4	63	70		63	70	68			
10	11	—	—	—	60	60	60	60	65														
2	1	2.4	65	70	65	70	71																



## LEGEND AND NOTES FOR TABLES 4A AND 4B

### LEGEND

- FLA** — Full Load Amps
- HACR** — Heating, Air Conditioning and Refrigeration
- IFM** — Indoor (Evaporator) Fan Motor
- LRA** — Locked Rotor Amps
- MCA** — Minimum Circuit Amps
- MOCP** — Maximum Overcurrent Protection
- NEC** — National Electrical Code
- OFM** — Outdoor (Condenser) Fan Motor
- RLA** — Rated Load Amps

\*Fuse or HACR circuit breaker.

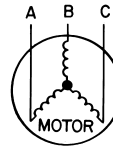


### NOTES:

1. In compliance with NEC requirements for multimotor and combination load equipment (refer to NEC Articles 430 and 440), the overcurrent protective device for the unit shall be fuse or HACR breaker. Canadian units may be fuse or circuit breaker.
2. **Unbalanced 3-Phase Supply Voltage**  
*Never operate a motor where a phase imbalance in supply voltage is greater than 2%.* Use the following formula to determine the percent voltage imbalance.

$$\% \text{ Voltage Imbalance} = 100 \times \frac{\text{max voltage deviation from average voltage}}{\text{average voltage}}$$

EXAMPLE: Supply voltage is 460-3-60.



$$\begin{aligned} \text{AB} &= 452 \text{ v} \\ \text{BC} &= 464 \text{ v} \\ \text{AC} &= 455 \text{ v} \\ \text{Average Voltage} &= \frac{452 + 464 + 455}{3} \\ &= \frac{1371}{3} \\ &= 457 \end{aligned}$$

Determine maximum deviation from average voltage.

$$\begin{aligned} (\text{AB}) \quad &457 - 452 = 5 \text{ v} \\ (\text{BC}) \quad &464 - 457 = 7 \text{ v} \\ (\text{AC}) \quad &457 - 455 = 2 \text{ v} \end{aligned}$$

Maximum deviation is 7 v.

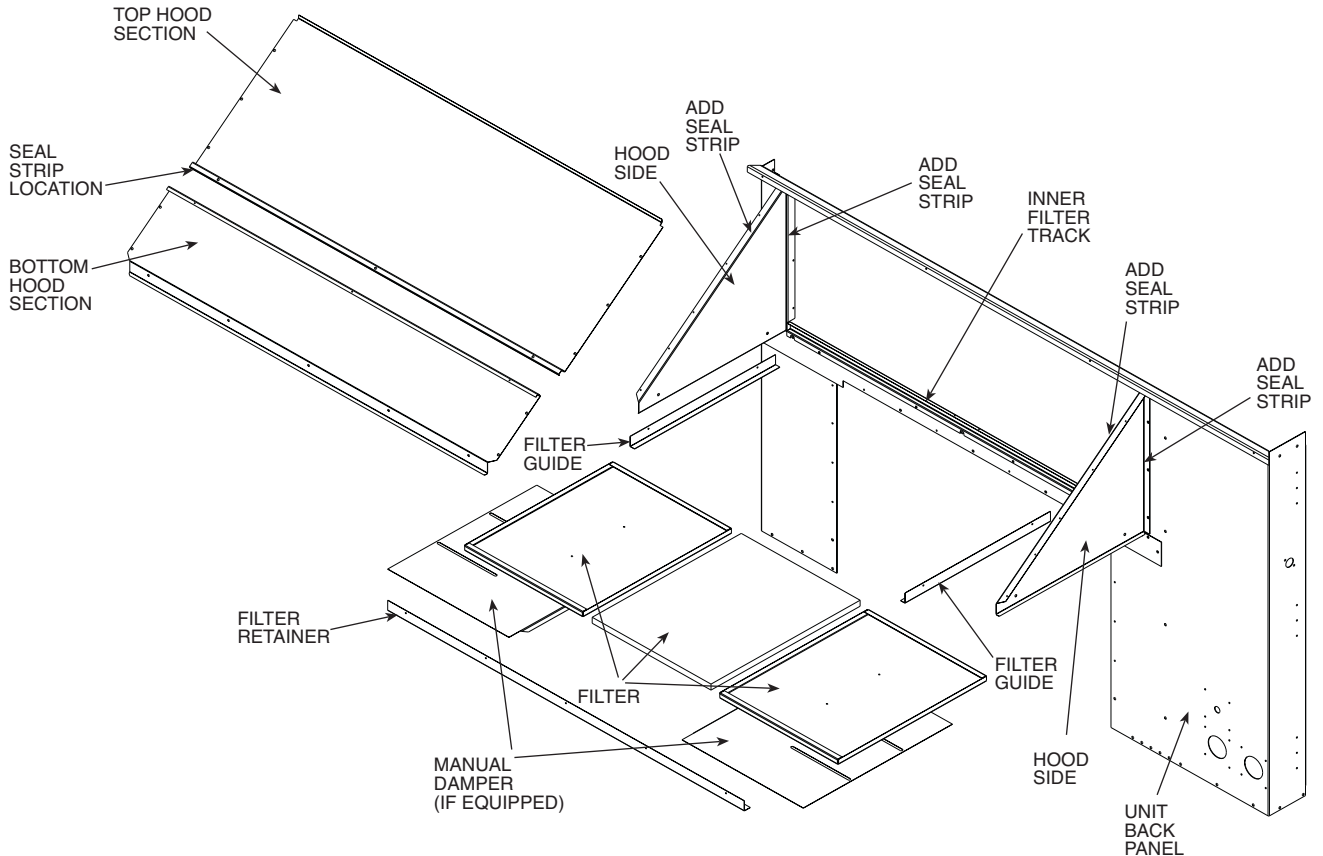
Determine percent voltage imbalance.

$$\begin{aligned} \% \text{ Voltage Imbalance} &= 100 \times \frac{7}{457} \\ &= 1.53\% \end{aligned}$$

This amount of phase imbalance is satisfactory as it is below the maximum allowable 2%.

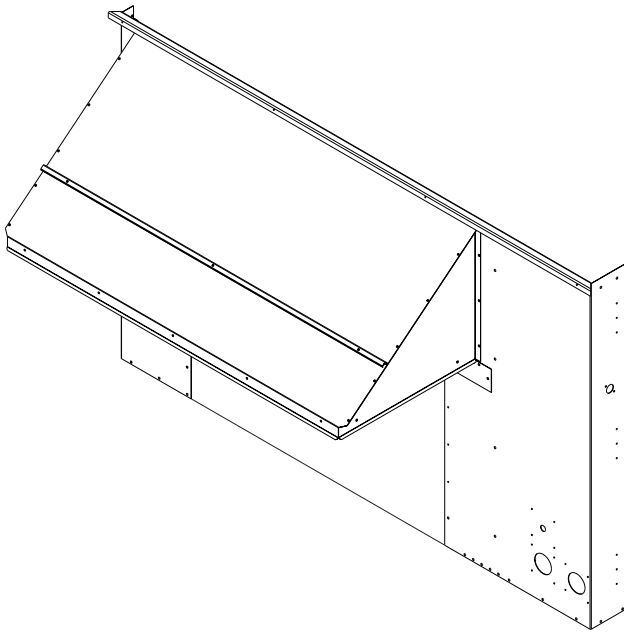
**IMPORTANT:** If the supply voltage phase imbalance is more than 2%, contact the local electric utility company immediately.

3. The convenience outlet full load amps (FLA) are 5, 3, and 3 for 208/230, 460, 575-V units, respectively.

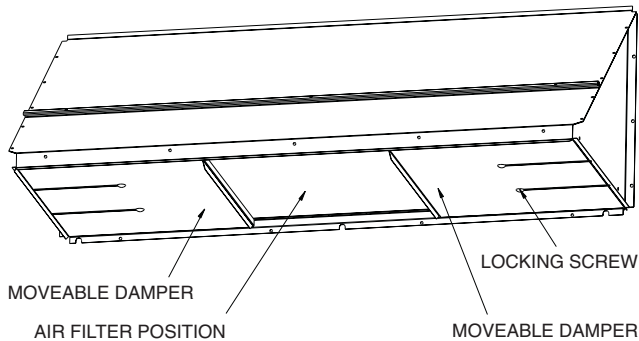


NOTE: Units with manual damper only use one filter.

**Fig. 18 — Outdoor-Air Hood Details**



**Fig. 19 — Outdoor-Air Hood Assembled**



**Fig. 20 — Manual Damper Details**

**Step 11 — Position Optional Power Exhaust or Barometric Relief Damper Hood** — The optional power exhaust or barometric relief dampers are shipped assembled and tilted back into the unit for shipping. Brackets and extra screws are shipped in shrink wrap around the dampers.

1. Remove 9 screws holding each damper assembly in place. See Fig. 21. Each damper assembly is secured with 3 screws on each side and 3 screws along the bottom. Save screws.

**⚠ CAUTION**

Be careful when tilting blower assembly. Hoods and blowers are heavy and can cause injury if dropped.

2. Pivot the damper assembly outward until top edge of the damper assembly rests against the inside wall of unit.
3. Secure each damper assembly to unit with 6 screws across top (3 screws provided) and bottom (3 screws from Step 1) of damper.
4. With screws saved from Step 1, install brackets on each side of damper assembly. See Fig. 22.
5. Remove tape from damper blades.

**Step 12 — Non-Fused Disconnect** — The handle for the factory-installed non-fused disconnect is shipped inside the unit to prevent the handle from damage during shipping. Follow these steps to complete installation of the handle.

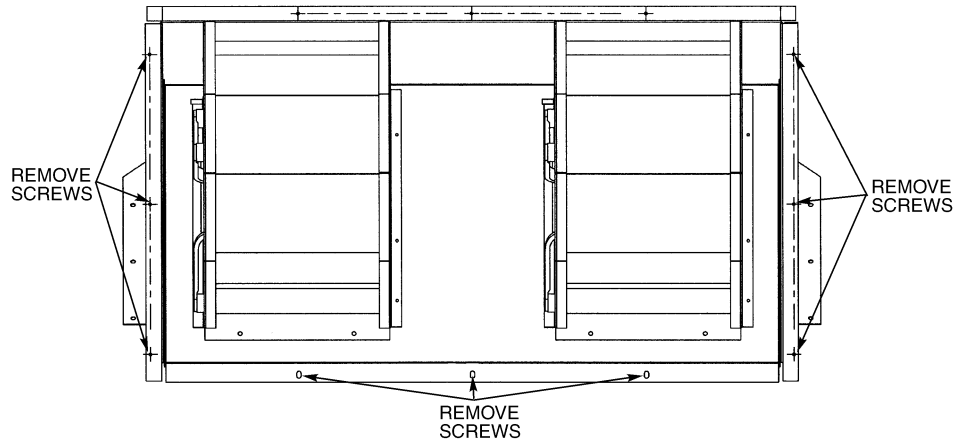
**⚠ WARNING**

BE SURE POWER IS SHUT OFF TO THE UNIT FROM THE BUILDING POWER SUPPLY. Electrical shock could cause personal injury.

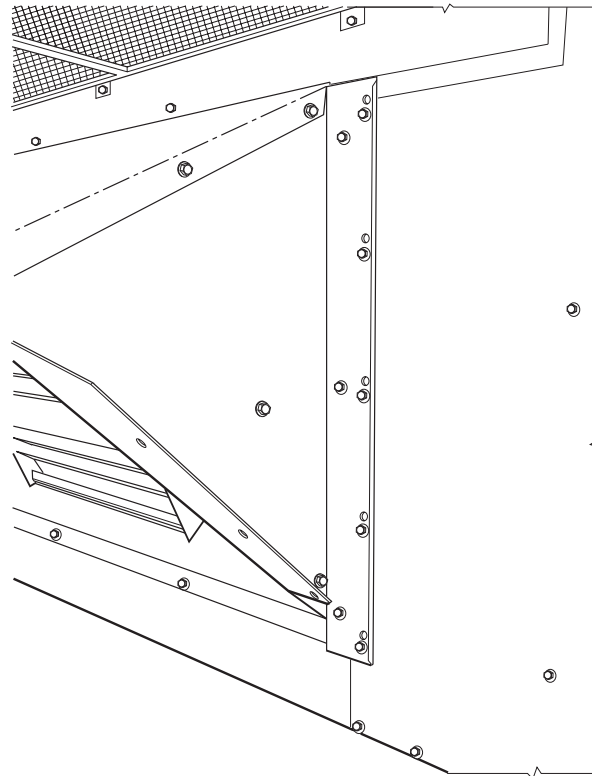
1. Open the control box access door.
2. Remove the small cover plate located on the unit corner post near the control section.
3. Remove the inner control box cover. The handle and shaft are located in a plastic bag at the bottom of the control box.
4. Insert the square shaft into the disconnect with the pins vertical. On the 100-amp disconnect, the shaft is keyed into the disconnect and can only be installed one way (with the pins vertical).
5. Insert the handle through the corner post and onto the shaft with the handle positioned so that “OFF” is on top.
6. Rotate the handle to the “ON” position to lock the pins into the handle.
7. From the inside of the corner post, attach the handle mounting screws to the handle. Slide the shaft fully into the handle and tighten the set screw(s) on the disconnect to lock the shaft. Tighten the screws that attach the handle to the corner post.
8. Rotate the handle back to the “OFF” position.
9. Replace all panels and doors. Power can now be turned back on to the unit.

**Step 13 — Install All Accessories** — After all of the factory-installed options have been adjusted, install all field-installed accessories. Refer to the accessory installation instructions included with each accessory. Consult the Carrier Price Pages for accessory package numbers for particular applications.





**Fig. 21 — Power Exhaust or Barometric Relief Damper Mounting Details**



**Fig. 22 — Bracket and Hood Positioning**

## PRE-START-UP

### **⚠ WARNING**

Failure to observe the following warnings could result in serious personal injury.

1. Follow recognized safety practices and wear protective goggles when checking or the servicing refrigerant system.
2. Do not operate the compressor or provide any electric power to the unit unless the compressor terminal cover is in place and secured.
3. Do not remove the compressor terminal cover until all electrical sources are disconnected.
4. Relieve all pressure from the system before touching or disturbing anything inside the compressor terminal box if refrigerant leak is suspected around the compressor terminals.
5. Never attempt to repair a soldered connection while the refrigerant system is under pressure.
6. Do not use torch to remove any component. The system contains oil and refrigerant under pressure. To remove a component, wear protective goggles and proceed as follows:
  - a. Shut off gas and then electrical power to the unit. Install lockout tag.
  - b. Relieve all pressure from the system using both high-pressure and low-pressure ports.
  - c. Cut the component connection tubing with a tubing cutter, and remove the component from the unit.
  - d. Carefully unsweat the remaining tubing stubs when necessary. Oil can ignite when exposed to torch flame.

Proceed as follows to inspect and prepare the unit for initial start-up:

1. Remove all access panels.
2. Read and follow instructions on all WARNING, CAUTION, and INFORMATION labels attached to, or shipped with, the unit.
3. Make the following inspections:
  - a. Inspect for shipping and handling damages such as broken lines, loose parts, or disconnected wires, etc.
  - b. Inspect for oil at all refrigerant tubing connections and on unit base. Detecting oil generally indicates a refrigerant leak. Leak-test all refrigerant tubing connections using an electronic leak detector, halide torch, or liquid-soap solution.
  - c. Inspect all field-wiring and factory-wiring connections. Be sure that connections are completed and tight.
  - d. Inspect coil fins. If damaged during shipping and handling, carefully straighten the fins with a fin comb.
4. Verify the following conditions:
  - a. Make sure that condenser fan blade is correctly positioned in the fan orifice. See Condenser-Fan Adjustment section on page 49 for more details.
  - b. Make sure that air filter(s) is in place.
  - c. Make sure that condensate drain trap is filled with water to ensure proper drainage.
  - d. Make sure that all tools and miscellaneous loose parts have been removed.

## START-UP

Use the following information and Start-Up Checklist on page CL-1 to check out unit PRIOR to start-up.

**Unit Preparation** — Check that unit has been installed in accordance with these installation instructions and all applicable codes.

**Compressor Mounting** — Compressors are internally spring mounted. Do not loosen or remove compressor hold-down bolts.

**Refrigerant Service Ports** — Each independent refrigerant system has a total of 3 Schrader-type service gage ports per circuit. One port is located on the suction line, one on the compressor discharge line, and one on the liquid line. Be sure that caps on the ports are tight.

**Crankcase Heater(s)** — Crankcase heaters are energized as long as there is power to the unit and the compressor is not operating.

**IMPORTANT:** Unit power must be on for 24 hours prior to start-up. Otherwise, damage to compressor may result.

**Compressor Rotation** — On 3-phase units, it is important to be certain the scroll compressor is rotating in the proper direction. To determine whether or not compressor is rotating in the proper direction:

1. Connect service gages to suction and discharge pressure fittings.
2. Energize the compressor.
3. The suction pressure should drop and the discharge pressure should rise, as is normal on any start-up.

If the suction pressure does not drop and the discharge pressure does not rise to normal levels:

1. Note that the evaporator fan is probably also rotating in the wrong direction.
2. Turn off power to the unit and install lockout tag.
3. Reverse any two of the unit power leads.
4. Turn on power to the unit.

The suction and discharge pressure levels should now move to their normal start-up levels.

**NOTE:** When the compressor is rotating in the wrong direction, the unit makes an elevated level of noise and does not provide heating or cooling.

### **⚠ CAUTION**

Compressor damage will occur if rotation is not immediately corrected.

**Internal Wiring** — Check all electrical connections in unit control boxes; tighten as required.

**Subcooler Heat Exchanger (SHX)** — The subcooler heat exchanger adds approximately 10 to 15° F of subcooling to the system. Check all valves and TXV (thermostatic expansion valve).

**Evaporator Fan** — Fan belt and variable pulleys are factory-installed. See Tables 5-23 for fan performance data. Be sure that fans rotate in the proper direction. See Table 24 for air quantity limits. See Table 25 for evaporator fan motor specifications. See Table 26 for accessory/FIOP static pressure. See Table 27 for fan rpm at various motor pulley settings. To alter fan performance, see Evaporator Fan Performance Adjustment section on page 48.

**Condenser Fans and Motors** — Condenser fans and motors are factory set. Refer to Condenser-Fan Adjustment section (page 49) as required.

**Return-Air Filters** — Check that correct filters are installed in filter tracks (see Table 1). Do not operate unit without return-air filters.

NOTE: For units with 4-in. filter option, units are shipped with standard 2-in. filters. To install 4-in. filters, the filter spacers must be removed.

**Outdoor-Air Inlet Screens** — Outdoor-air inlet screens must be in place before operating unit.

**Gas Heat** — Verify gas pressures before turning on heat as follows:

1. Turn off field-supplied manual gas stop, located external to unit.
2. Connect pressure gage to supply gas tap, located on field-supplied manual shutoff valve (see Fig. 14).

3. Connect pressure gage to manifold pressure tap.
4. Turn on field-supplied manual gas stop. Temporarily install the jumper wire between “R” and “W1” on TB2. Set thermostat to HEAT and raise set point until heat comes on.
5. After the unit has run for several minutes, verify the supply gas pressure is between 5.5 in. wg to 13.0 in. wg, and the manifold pressure is 2.95 in. wg on horizontal discharge applications and 3.00 on vertical discharge applications. If manifold pressure must be adjusted, refer to Gas Valve Adjustment section.

NOTE: Supply gas pressure must not exceed 13.0 in. wg.

6. Set thermostat to OFF.
7. Remove jumper wire if the unit will be operating under thermostat mode.
8. Return thermostat to desired set point.

**Table 5 — Fan Performance — 48PGD20 Vertical Supply/Return Units**

AIRFLOW (Cfm)	AVAILABLE EXTERNAL STATIC PRESSURE (in. wg)									
	0.2		0.4		0.6		0.8		1.0	
	Rpm	Bhp	Rpm	Bhp	Rpm	Bhp	Rpm	Bhp	Rpm	Bhp
5000	590	1.47	663	1.74	727	2.01	786	2.26	840	2.52
5500	633	1.82	703	2.11	764	2.40	820	2.67	A 872	2.94
6000	677	2.21	744	2.53	A 803	2.84	A 857	3.13	907	3.42
6500	722	2.67	A 786	3.01	842	3.33	894	3.64	942	3.95
7000	A 767	3.17	828	3.53	883	3.88	933	4.21	B 979	4.53
7500	813	3.74	871	4.12	924	4.48	B 972	4.83	B 1017	5.18
8000	859	4.36	915	4.77	B 966	5.15	B 1012	5.52	1056	5.88
8500	906	5.05	B 959	5.47	C 1008	5.87	C 1053	6.26	C 1096	6.64
9000	C 952	5.81	C 1004	6.25	1051	6.67	1095	7.07	1136	7.47

AIRFLOW (Cfm)	AVAILABLE EXTERNAL STATIC PRESSURE (in. wg)									
	1.2		1.4		1.6		1.8		2.0	
	Rpm	Bhp	Rpm	Bhp	Rpm	Bhp	Rpm	Bhp	Rpm	Bhp
5000	891	2.77	940	3.02	987	3.27	1032	3.52	1076	3.77
5500	A 921	3.21	968	3.48	1014	3.74	B 1057	4.01	B 1099	4.27
6000	954	3.70	B 999	3.99	B 1042	4.27	B 1084	4.55	B 1125	4.83
6500	988	4.25	1032	4.55	1073	4.85	1114	5.14	1153	5.44
7000	B 1024	4.85	1066	5.17	1106	5.48	C 1145	5.79	1183	6.10
7500	1060	5.51	1101	5.84	C 1140	6.17	1178	6.50	D 1215	6.82
8000	1098	6.23	C 1138	6.58	1176	6.92	D 1213	7.26	D 1249	7.60
8500	C 1137	7.01	1175	7.38	D 1212	7.74	1248	8.09	1283	8.45
9000	1176	7.86	D 1214	8.24	1250	8.61	1285	8.99	1319	9.36

LEGEND

**Bhp** — Brake Horsepower Input to Fan

**Boldface** indicates field-supplied motor/drive required.

NOTES:

1. Motor drive ranges:  
 (A) Low Range: 685-939 rpm, 4.26 bhp (208/230 and 460-v), 751-954 rpm, 5.75 bhp (575-v)  
 (B) Mid-Low Range: 949-1206 rpm, 5.75 bhp  
 (C) Mid-High Range: 941-1176 rpm, 8.63 bhp  
 (D) High Range: 1014-1297 rpm, 11.50 bhp  
 All other rpms require field-supplied motor or drive.
2. See page 36 for general fan performance notes.

**Table 6 — Fan Performance — 48PGE20 — Vertical Supply/Return Units**

AIRFLOW (Cfm)	AVAILABLE EXTERNAL STATIC PRESSURE (in. wg)									
	0.2		0.4		0.6		0.8		1.0	
	Rpm	Bhp	Rpm	Bhp	Rpm	Bhp	Rpm	Bhp	Rpm	Bhp
5000	<b>607</b>	<b>1.53</b>	<b>677</b>	<b>1.80</b>	740	2.06	797	2.31	850	2.57
5500	<b>652</b>	<b>1.90</b>	719	2.19	779	2.47	<b>A</b> 833	2.74	<b>A</b> 884	3.01
6000	699	2.32	<b>A</b> 763	2.63	<b>A</b> 819	2.93	<b>A</b> 872	3.22	<b>A</b> 921	3.50
6500	<b>A</b> 746	2.79	<b>A</b> 807	3.12	861	3.44	911	3.75	958	4.05
7000	794	3.33	851	3.68	904	4.02	952	4.34	<b>B</b> 998	4.66
7500	842	3.93	<b>897</b>	<b>4.30</b>	<b>947</b>	<b>4.65</b>	<b>B</b> 994	5.00	1038	5.33
8000	<b>891</b>	<b>4.59</b>	<b>943</b>	<b>4.98</b>	<b>B</b> 991	5.35	1036	5.71	1079	6.07
8500	940	5.32	<b>B</b> 990	5.72	<b>C</b> 1036	6.11	<b>C</b> 1080	6.49	<b>C</b> 1121	6.87
9000	<b>C</b> 990	6.12	<b>C</b> 1037	6.54	<b>C</b> 1082	6.95	<b>C</b> 1124	7.35	1163	7.73

AIRFLOW (Cfm)	AVAILABLE EXTERNAL STATIC PRESSURE (in. wg)									
	1.2		1.4		1.6		1.8		2.0	
	Rpm	Bhp	Rpm	Bhp	Rpm	Bhp	Rpm	Bhp	Rpm	Bhp
5000	900	2.82	949	3.06	995	3.31	1040	3.56	1083	3.81
5500	<b>A</b> 933	3.27	979	3.54	1023	3.80	<b>B</b> 1066	4.06	<b>B</b> 1108	4.33
6000	967	3.79	<b>B</b> 1011	4.07	<b>B</b> 1054	4.35	<b>B</b> 1095	4.62	<b>B</b> 1135	4.90
6500	1003	4.35	1046	4.65	1087	4.94	1127	5.24	1165	5.53
7000	<b>B</b> 1041	4.98	1082	5.29	1122	5.60	<b>C</b> 1160	5.91	1197	6.22
7500	1079	5.67	<b>C</b> 1119	5.99	<b>C</b> 1158	6.32	1195	6.64	<b>D</b> 1231	6.96
8000	1119	6.42	1158	6.76	1195	7.10	<b>D</b> 1231	7.44	1267	7.78
8500	<b>C</b> 1160	7.23	<b>D</b> 1198	7.59	<b>D</b> 1234	7.95	1269	8.30	<b>1303</b>	<b>8.65</b>
9000	<b>D</b> 1202	8.12	<b>D</b> 1238	8.49	1273	8.87	<b>1308</b>	<b>9.23</b>	<b>1341</b>	<b>9.60</b>

LEGEND

**Bhp** — Brake Horsepower Input to Fan

**Boldface** indicates field-supplied motor/drive required.

NOTES:

- Motor drive ranges:  
**(A)** Low Range: 685-939 rpm, 4.26 bhp (208/230 and 460-v), 751-954 rpm, 5.75 bhp (575-v)  
**(B)** Mid-Low Range: 949-1206 rpm, 5.75 bhp  
**(C)** Mid-High Range: 941-1176 rpm, 8.63 bhp  
**(D)** High Range: 1014-1297 rpm, 11.50 bhp  
 All other rpms require field-supplied motor or drive.

- See page 36 for general fan performance notes.

**Table 7 — Fan Performance — 48PGF20 — Vertical Supply/Return Units**

AIRFLOW (Cfm)	AVAILABLE EXTERNAL STATIC PRESSURE (in. wg)									
	0.2		0.4		0.6		0.8		1.0	
	Rpm	Bhp	Rpm	Bhp	Rpm	Bhp	Rpm	Bhp	Rpm	Bhp
5000	<b>607</b>	<b>1.53</b>	<b>677</b>	<b>1.80</b>	740	2.06	797	2.31	850	2.57
5500	<b>652</b>	<b>1.90</b>	719	2.19	779	2.47	<b>A</b> 833	2.74	<b>A</b> 884	3.01
6000	699	2.32	<b>A</b> 763	2.63	<b>A</b> 819	2.93	<b>A</b> 872	3.22	<b>A</b> 921	3.50
6500	<b>A</b> 746	2.79	<b>A</b> 807	3.12	861	3.44	911	3.75	958	4.05
7000	794	3.33	851	3.68	904	4.02	952	4.34	<b>B</b> 998	4.66
7500	842	3.93	<b>897</b>	<b>4.30</b>	<b>947</b>	<b>4.65</b>	<b>B</b> 994	5.00	1038	5.33
8000	<b>891</b>	<b>4.59</b>	<b>943</b>	<b>4.98</b>	<b>B</b> 991	5.35	1036	5.71	1079	6.07
8500	<b>940</b>	<b>5.32</b>	<b>B</b> 990	5.72	1036	6.11	1080	6.49	<b>C</b> 1121	6.87
9000	<b>C</b> 990	6.12	<b>C</b> 1037	6.54	<b>C</b> 1082	6.95	<b>C</b> 1124	7.35	1163	7.73

AIRFLOW (Cfm)	AVAILABLE EXTERNAL STATIC PRESSURE (in. wg)									
	1.2		1.4		1.6		1.8		2.0	
	Rpm	Bhp	Rpm	Bhp	Rpm	Bhp	Rpm	Bhp	Rpm	Bhp
5000	<b>A</b> 900	2.82	949	3.06	995	3.31	1040	3.56	1083	3.81
5500	933	3.27	979	3.54	1023	3.80	<b>B</b> 1066	4.06	<b>B</b> 1108	4.33
6000	967	3.79	<b>B</b> 1011	4.07	<b>B</b> 1054	4.35	<b>B</b> 1095	4.62	<b>B</b> 1135	4.90
6500	<b>B</b> 1003	4.35	1046	4.65	1087	4.94	1127	5.24	1165	5.53
7000	1041	4.98	1082	5.29	1122	5.60	<b>C</b> 1160	5.91	1197	6.22
7500	1079	5.67	1119	5.99	<b>C</b> 1158	6.32	1195	6.64	<b>D</b> 1231	6.96
8000	<b>C</b> 1119	6.42	<b>C</b> 1158	6.76	1195	7.10	<b>D</b> 1231	7.44	1267	7.78
8500	1160	7.23	<b>D</b> 1198	7.59	<b>D</b> 1234	7.95	1269	8.30	<b>1303</b>	<b>8.65</b>
9000	<b>D</b> 1202	8.12	<b>D</b> 1238	8.49	1273	8.87	<b>1308</b>	<b>9.23</b>	<b>1341</b>	<b>9.60</b>

LEGEND

**Bhp** — Brake Horsepower Input to Fan

**Boldface** indicates field-supplied motor/drive required.

NOTES:

- Motor drive ranges:  
**(A)** Low Range: 685-939 rpm, 4.26 bhp (208/230 and 460-v), 751-954 rpm, 5.75 bhp (575-v)  
**(B)** Mid-Low Range: 949-1206 rpm, 5.75 bhp  
**(C)** Mid-High Range: 941-1176 rpm, 8.63 bhp  
**(D)** High Range: 1014-1297 rpm, 11.50 bhp  
 All other rpms require field-supplied motor or drive.
- See page 36 for general fan performance notes.

**Table 8 — Fan Performance — 48PGD24 — Vertical Supply/Return Units**

AIRFLOW (Cfm)	AVAILABLE EXTERNAL STATIC PRESSURE (in. wg)									
	0.2		0.4		0.6		0.8		1.0	
	Rpm	Bhp	Rpm	Bhp	Rpm	Bhp	Rpm	Bhp	Rpm	Bhp
5,500	<b>633</b>	<b>1.82</b>	703	2.11	764	2.40	820	2.67	A 872	2.94
6,000	<b>677</b>	<b>2.21</b>	744	2.53	A 803	2.84	A 857	3.13	907	3.42
6,500	722	2.67	A 786	3.01	A 842	3.33	A 894	3.64	<b>942</b>	<b>3.95</b>
7,000	A 767	3.17	828	3.53	883	3.88	933	4.21	B 979	4.53
7,500	813	3.74	871	4.12	<b>924</b>	<b>4.48</b>	B 972	4.83	B 1017	5.18
8,000	<b>859</b>	<b>4.36</b>	<b>915</b>	<b>4.77</b>	B 966	5.15	B 1012	5.52	1056	5.88
8,500	<b>906</b>	<b>5.05</b>	B 959	5.47	1008	5.87	1053	6.26	C 1096	6.64
9,000	952	5.81	1004	6.25	C 1051	6.67	C 1095	7.07	1136	7.47
9,500	C 999	6.63	C 1049	7.09	C 1094	7.53	C 1137	7.95	D 1177	8.36
10,000	1047	7.53	1094	8.00	1138	8.46	D 1180	8.90	D 1219	9.33

AIRFLOW (Cfm)	AVAILABLE EXTERNAL STATIC PRESSURE (in. wg)									
	1.2		1.4		1.6		1.8		2.0	
	Rpm	Bhp	Rpm	Bhp	Rpm	Bhp	Rpm	Bhp	Rpm	Bhp
5,500	A 921	3.21	968	3.48	1014	3.74	1057	4.01	1099	4.27
6,000	954	3.70	999	3.99	1042	4.27	B 1084	4.55	B 1125	4.83
6,500	988	4.25	B 1032	4.55	B 1073	4.85	1114	5.14	1153	5.44
7,000	B 1024	4.85	1066	5.17	1106	5.48	C 1145	5.79	1183	6.10
7,500	1060	5.51	1101	5.84	1140	6.17	1178	6.50	D 1215	6.82
8,000	1098	6.23	C 1138	6.58	1176	6.92	1213	7.26	D 1249	7.60
8,500	C 1137	7.01	1175	7.38	1212	7.74	D 1248	8.09	1283	8.45
9,000	1176	7.86	1214	8.24	D 1250	8.61	1285	8.99	<b>1319</b>	<b>9.36</b>
9,500	1216	8.77	D 1253	9.17	1288	9.56	<b>1322</b>	<b>9.95</b>	<b>1355</b>	<b>10.33</b>
10,000	D 1256	9.75	1292	10.16	<b>1327</b>	<b>10.57</b>	<b>1360</b>	<b>10.98</b>	<b>1393</b>	<b>11.38</b>

LEGEND

**Bhp** — Brake Horsepower Input to Fan

**Boldface** indicates field-supplied motor/drive required.

NOTES:

1. Motor drive ranges:

- (A) Low Range: 685-939 rpm, 4.26 bhp (208/230 and 460-v), 751-954 rpm, 5.75 bhp (575-v)
- (B) Mid-Low Range: 949-1206 rpm, 5.75 bhp
- (C) Mid-High Range: 941-1176 rpm, 8.63 bhp
- (D) High Range: 1014-1297 rpm, 11.50 bhp

All other rpms require field-supplied motor or drive.

2. See page 36 for general fan performance notes.

**Table 9 — Fan Performance — 48PGE24 — Vertical Supply/Return Units**

AIRFLOW (Cfm)	AVAILABLE EXTERNAL STATIC PRESSURE (in. wg)									
	0.2		0.4		0.6		0.8		1.0	
	Rpm	Bhp	Rpm	Bhp	Rpm	Bhp	Rpm	Bhp	Rpm	Bhp
5,500	<b>652</b>	<b>1.90</b>	719	2.19	779	2.47	833	2.74	A 884	3.01
6,000	699	2.32	A 763	2.63	A 819	2.93	A 872	3.22	A 921	3.50
6,500	746	2.79	A 807	3.12	A 861	3.44	A 911	3.75	958	4.05
7,000	794	3.33	851	3.68	904	4.02	952	4.34	B 998	4.66
7,500	842	3.93	<b>897</b>	<b>4.30</b>	<b>947</b>	<b>4.65</b>	B 994	5.00	1038	5.33
8,000	<b>891</b>	<b>4.59</b>	<b>943</b>	<b>4.98</b>	B 991	5.35	1036	5.71	1079	6.07
8,500	940	5.32	B 990	5.72	1036	6.11	1080	6.49	C 1121	6.87
9,000	990	6.12	1037	6.54	C 1082	6.95	C 1124	7.35	1163	7.73
9,500	1039	7.00	C 1085	7.43	1128	7.85	1168	8.27	1207	8.67
10,000	1089	7.95	1133	8.40	D 1174	8.83	D 1213	9.26	D 1251	9.69

AIRFLOW (Cfm)	AVAILABLE EXTERNAL STATIC PRESSURE (in. wg)									
	1.2		1.4		1.6		1.8		2.0	
	Rpm	Bhp	Rpm	Bhp	Rpm	Bhp	Rpm	Bhp	Rpm	Bhp
5,500	A 933	3.27	979	3.54	1023	3.80	1066	4.06	1108	4.33
6,000	967	3.79	1011	4.07	1054	4.35	B 1095	4.62	B 1135	4.90
6,500	1003	4.35	B 1046	4.65	B 1087	4.94	1127	5.24	1165	5.53
7,000	B 1041	4.98	1082	5.29	1122	5.60	C 1160	5.91	1197	6.22
7,500	1079	5.67	1119	5.99	C 1158	6.32	1195	6.64	D 1231	6.96
8,000	C 1119	6.42	1158	6.76	1195	7.10	D 1231	7.44	1267	7.78
8,500	1160	7.23	1198	7.59	D 1234	7.95	1269	8.30	<b>1303</b>	<b>8.65</b>
9,000	1202	8.12	D 1238	8.49	1273	8.87	<b>1308</b>	<b>9.23</b>	<b>1341</b>	<b>9.60</b>
9,500	D 1244	9.07	1279	9.46	<b>1314</b>	<b>9.85</b>	<b>1347</b>	<b>10.24</b>	<b>1379</b>	<b>10.62</b>
10,000	1287	10.10	<b>1321</b>	<b>10.51</b>	<b>1355</b>	<b>10.91</b>	<b>1387</b>	<b>11.31</b>	—	—

LEGEND

**Bhp** — Brake Horsepower Input to Fan

**Boldface** indicates field-supplied motor/drive required.

NOTES:

- Motor drive ranges:  
**(A)** Low Range: 685-939 rpm, 4.26 bhp (208/230 and 460-v), 751-954 rpm, 5.75 bhp (575-v)  
**(B)** Mid-Low Range: 949-1206 rpm, 5.75 bhp  
**(C)** Mid-High Range: 941-1176 rpm, 8.63 bhp  
**(D)** High Range: 1014-1297 rpm, 11.50 bhp  
 All other rpms require field-supplied motor or drive.
- See page 36 for general fan performance notes.

**Table 10 — Fan Performance — 48PGF24 Vertical Supply/Return Units**

AIRFLOW (Cfm)	AVAILABLE EXTERNAL STATIC PRESSURE (in. wg)									
	0.2		0.4		0.6		0.8		1.0	
	Rpm	Bhp	Rpm	Bhp	Rpm	Bhp	Rpm	Bhp	Rpm	Bhp
5,500	<b>652</b>	<b>1.90</b>	719	2.19	779	2.47	833	2.74	A 884	3.01
6,000	699	2.32	A 763	2.63	A 819	2.93	A 872	3.22	A 921	3.50
6,500	746	2.79	807	3.12	A 861	3.44	911	3.75	958	4.05
7,000	794	3.33	851	3.68	904	4.02	952	4.34	B 998	4.66
7,500	842	3.93	<b>897</b>	<b>4.30</b>	<b>947</b>	<b>4.65</b>	B 994	5.00	1038	5.33
8,000	<b>891</b>	<b>4.59</b>	<b>943</b>	<b>4.98</b>	B 991	5.35	1036	5.71	1079	6.07
8,500	<b>940</b>	<b>5.32</b>	B 990	5.72	1036	6.11	1080	6.49	C 1121	6.87
9,000	990	6.12	1037	6.54	C 1082	6.95	C 1124	7.35	1163	7.73
9,500	C 1039	7.00	C 1085	7.43	1128	7.85	1168	8.27	D 1207	8.67
10,000	1089	7.95	1133	8.40	D 1174	8.83	D 1213	9.26	D 1251	9.69

AIRFLOW (Cfm)	AVAILABLE EXTERNAL STATIC PRESSURE (in. wg)									
	1.2		1.4		1.6		1.8		2.0	
	Rpm	Bhp	Rpm	Bhp	Rpm	Bhp	Rpm	Bhp	Rpm	Bhp
5,500	A 933	3.27	979	3.54	1023	3.80	1066	4.06	1108	4.33
6,000	967	3.79	1011	4.07	1054	4.35	B 1095	4.62	B 1135	4.90
6,500	1003	4.35	B 1046	4.65	B 1087	4.94	1127	5.24	1165	5.53
7,000	B 1041	4.98	1082	5.29	1122	5.60	C 1160	5.91	1197	6.22
7,500	1079	5.67	1119	5.99	C 1158	6.32	1195	6.64	D 1231	6.96
8,000	1119	6.42	C 1158	6.76	1195	7.10	D 1231	7.44	1267	7.78
8,500	C 1160	7.23	1198	7.59	D 1234	7.95	1269	8.30	<b>1303</b>	<b>8.65</b>
9,000	1202	8.12	D 1238	8.49	1273	8.87	<b>1308</b>	<b>9.23</b>	<b>1341</b>	<b>9.60</b>
9,500	D 1244	9.07	1279	9.46	<b>1314</b>	<b>9.85</b>	<b>1347</b>	<b>10.24</b>	<b>1379</b>	<b>10.62</b>
10,000	1287	10.10	<b>1321</b>	<b>10.51</b>	<b>1355</b>	<b>10.91</b>	<b>1387</b>	<b>11.31</b>	—	—

LEGEND

**Bhp** — Brake Horsepower Input to Fan

**Boldface** indicates field-supplied motor/drive required.

NOTES:

- Motor drive ranges:  
**(A)** Low Range: 685-939 rpm, 4.26 bhp (208/230 and 460-v), 751-954 rpm, 5.75 bhp (575-v)  
**(B)** Mid-Low Range: 949-1206 rpm, 5.75 bhp  
**(C)** Mid-High Range: 941-1176 rpm, 8.63 bhp  
**(D)** High Range: 1014-1297 rpm, 11.50 bhp  
 All other rpms require field-supplied motor or drive.
- See page 36 for general fan performance notes.



Table 11 — Fan Performance — 48PGD28 — Vertical Supply/Return Units

AIRFLOW (Cfm)	AVAILABLE EXTERNAL STATIC PRESSURE (in. wg)									
	0.2		0.4		0.6		0.8		1.0	
	Rpm	Bhp	Rpm	Bhp	Rpm	Bhp	Rpm	Bhp	Rpm	Bhp
6,500	750	2.28	A 806	2.62	A 854	2.93	898	3.25	B 943	3.59
7,000	A 797	2.78	853	3.17	899	3.50	B 941	3.84	B 982	4.18
7,500	845	3.34	900	3.78	B 945	4.15	985	4.51	1024	4.87
8,000	892	3.97	B 948	4.48	991	4.88	1030	5.26	1067	5.64
8,500	B 939	4.68	995	5.25	1038	5.69	C 1076	6.10	C 1112	6.50
9,000	986	5.46	1042	6.10	C 1085	6.59	C 1122	7.04	1157	7.46
9,500	1033	6.32	C 1090	7.04	1132	7.59	1169	8.07	1203	8.52
10,000	C 1079	7.26	1137	8.07	1180	8.67	D 1216	9.19	D 1249	9.68
10,500	1126	8.28	D 1184	9.20	D 1227	9.86	D 1263	10.43	D 1296	10.95
11,000	1172	9.40	D 1232	10.42	1274	11.15	<b>1310</b>	<b>11.76</b>	<b>1342</b>	<b>12.33</b>
11,500	D 1219	10.61	<b>1279</b>	<b>11.74</b>	<b>1322</b>	<b>12.54</b>	<b>1357</b>	<b>13.21</b>	—	—
12,000	<b>1265</b>	<b>11.91</b>	<b>1326</b>	<b>13.17</b>	—	—	—	—	—	—
12,500	<b>1311</b>	<b>13.32</b>	—	—	—	—	—	—	—	—

AIRFLOW (Cfm)	AVAILABLE EXTERNAL STATIC PRESSURE (in. wg)									
	1.2		1.4		1.6		1.8		2.0	
	Rpm	Bhp	Rpm	Bhp	Rpm	Bhp	Rpm	Bhp	Rpm	Bhp
6,500	B 988	3.97	1035	4.40	1082	4.87	C 1130	5.39	1177	5.95
7,000	1024	4.56	C 1066	4.98	C 1109	5.43	1153	5.94	1197	6.48
7,500	C 1063	5.25	1101	5.66	C 1141	6.10	1181	6.59	D 1222	7.12
8,000	1104	6.03	1140	6.44	1176	6.88	D 1213	7.36	1251	7.87
8,500	1146	6.91	1180	7.33	1214	7.77	1249	8.24	1283	8.74
9,000	1190	7.89	D 1222	8.32	D 1255	8.77	1287	9.24	<b>1319</b>	<b>9.74</b>
9,500	D 1235	8.97	1266	9.42	1296	9.88	<b>1327</b>	<b>10.36</b>	<b>1357</b>	<b>10.86</b>
10,000	1280	10.16	<b>1310</b>	<b>10.63</b>	<b>1340</b>	<b>11.10</b>	<b>1369</b>	<b>11.59</b>	<b>1398</b>	<b>12.09</b>
10,500	<b>1326</b>	<b>11.45</b>	<b>1355</b>	<b>11.95</b>	<b>1384</b>	<b>12.44</b>	—	—	—	—
11,000	<b>1372</b>	<b>12.86</b>	—	—	—	—	—	—	—	—
11,500	—	—	—	—	—	—	—	—	—	—
12,000	—	—	—	—	—	—	—	—	—	—
12,500	—	—	—	—	—	—	—	—	—	—

LEGEND

**Bhp** — Brake Horsepower Input to Fan

**Boldface** indicates field-supplied motor/drive required.

NOTES:

1. Motor drive ranges:

- (A) Low Range: 687-873 rpm, 5.75 bhp
- (B) Mid-Low Range: 805-1007 rpm, 5.75 bhp
- (C) Mid-High Range: 941-1176 rpm, 8.63 bhp
- (D) High Range: 1014-1297 rpm, 11.50 bhp

All other rpms require field-supplied motor or drive.

2. See page 36 for general fan performance notes.

**Table 12 — Fan Performance — 48PGE28 — Vertical Supply/Return Units**

AIRFLOW (Cfm)	AVAILABLE EXTERNAL STATIC PRESSURE (in. wg)									
	0.2		0.4		0.6		0.8		1.0	
	Rpm	Bhp	Rpm	Bhp	Rpm	Bhp	Rpm	Bhp	Rpm	Bhp
6,500	A 775	2.43	A 825	2.75	A 871	3.05	915	3.37	B 959	3.72
7,000	826	2.98	875	3.22	B 918	3.58	B 959	3.98	B 1000	4.34
7,500	878	3.60	B 925	3.89	B 966	4.28	1005	4.69	1043	5.05
8,000	B 929	4.31	975	4.73	1015	5.11	1052	5.48	C 1088	5.86
8,500	981	5.11	1026	5.56	C 1064	5.97	C 1100	6.37	1134	6.76
9,000	1033	6.00	C 1076	6.49	1114	6.94	1148	7.36	1181	7.77
9,500	C 1085	6.98	1128	7.53	1164	8.00	1198	8.45	D 1229	8.89
10,000	1137	8.08	1179	8.66	D 1214	9.18	D 1247	9.65	1278	10.12
10,500	D 1190	9.28	D 1230	9.91	1265	10.46	1297	10.97	<b>1327</b>	<b>11.47</b>
11,000	1242	10.60	1282	11.28	<b>1316</b>	<b>11.86</b>	<b>1347</b>	<b>12.41</b>	<b>1376</b>	<b>12.93</b>
11,500	<b>1294</b>	<b>12.04</b>	<b>1333</b>	<b>12.76</b>	<b>1367</b>	<b>13.39</b>	—	—	—	—
12,000	<b>1347</b>	<b>13.60</b>	—	—	—	—	—	—	—	—
12,500	—	—	—	—	—	—	—	—	—	—

AIRFLOW (Cfm)	AVAILABLE EXTERNAL STATIC PRESSURE (in. wg)									
	1.2		1.4		1.6		1.8		2.0	
	Rpm	Bhp	Rpm	Bhp	Rpm	Bhp	Rpm	Bhp	Rpm	Bhp
6,500	B 1004	4.11	1050	4.55	1098	5.04	C 1145	5.57	1192	6.14
7,000	1041	4.73	C 1083	5.15	C 1126	5.62	1170	6.14	D 1214	6.70
7,500	C 1081	5.44	1120	5.86	1159	6.32	1199	6.82	1240	7.36
8,000	1124	6.26	1160	6.68	1196	7.13	D 1233	7.62	1270	8.15
8,500	1168	7.17	1202	7.60	D 1235	8.06	1269	8.54	<b>1304</b>	<b>9.05</b>
9,000	D 1214	8.20	D 1245	8.64	1277	9.10	<b>1309</b>	<b>9.58</b>	<b>1341</b>	<b>10.09</b>
9,500	1260	9.33	1290	9.79	<b>1320</b>	<b>10.25</b>	<b>1351</b>	<b>10.74</b>	<b>1381</b>	<b>11.25</b>
10,000	<b>1308</b>	<b>10.58</b>	<b>1337</b>	<b>11.05</b>	<b>1365</b>	<b>11.53</b>	<b>1394</b>	<b>12.03</b>	—	—
10,500	<b>1356</b>	<b>11.95</b>	<b>1384</b>	<b>12.44</b>	—	—	—	—	—	—
11,000	—	—	—	—	—	—	—	—	—	—
11,500	—	—	—	—	—	—	—	—	—	—
12,000	—	—	—	—	—	—	—	—	—	—
12,500	—	—	—	—	—	—	—	—	—	—

LEGEND

**Bhp** — Brake Horsepower Input to Fan

**Boldface** indicates field-supplied motor/drive required.

NOTES:

1. Motor drive ranges:

- (A) Low Range: 687-873 rpm, 5.75 bhp
- (B) Mid-Low Range: 805-1007 rpm, 5.75 bhp
- (C) Mid-High Range: 941-1176 rpm, 8.63 bhp
- (D) High Range: 1014-1297 rpm, 11.50 bhp

All other rpms require field-supplied motor or drive.

2. See page 36 for general fan performance notes.

**Table 13 — Fan Performance — 48PGF28 — Vertical Supply/Return Units**

AIRFLOW (Cfm)	AVAILABLE EXTERNAL STATIC PRESSURE (in. wg)									
	0.2		0.4		0.6		0.8		1.0	
	Rpm	Bhp	Rpm	Bhp	Rpm	Bhp	Rpm	Bhp	Rpm	Bhp
6,500	A 775	2.43	A 825	2.75	A 871	3.05	915	3.37	B 959	3.72
7,000	826	2.98	875	3.22	B 918	3.58	B 959	3.98	1000	4.34
7,500	878	3.60	B 925	3.89	B 966	4.28	1005	4.69	1043	5.05
8,000	B 929	4.31	975	4.73	1015	5.11	1052	5.48	C 1088	5.86
8,500	981	5.11	1026	5.56	C 1064	5.97	C 1100	6.37	1134	6.76
9,000	1033	6.00	C 1076	6.49	1114	6.94	1148	7.36	1181	7.77
9,500	C 1085	6.98	1128	7.53	1164	8.00	1198	8.45	D 1229	8.89
10,000	1137	8.08	1179	8.66	D 1214	9.18	D 1247	9.65	1278	10.12
10,500	D 1190	9.28	D 1230	9.91	1265	10.46	1297	10.97	1327	11.47
11,000	1242	10.60	1282	11.28	<b>1316</b>	<b>11.86</b>	<b>1347</b>	<b>12.41</b>	<b>1376</b>	<b>12.93</b>
11,500	<b>1294</b>	<b>12.04</b>	<b>1333</b>	<b>12.76</b>	<b>1367</b>	<b>13.39</b>	—	—	—	—
12,000	<b>1347</b>	<b>13.60</b>	—	—	—	—	—	—	—	—
12,500	—	—	—	—	—	—	—	—	—	—

AIRFLOW (Cfm)	AVAILABLE EXTERNAL STATIC PRESSURE (in. wg)									
	1.2		1.4		1.6		1.8		2.0	
	Rpm	Bhp	Rpm	Bhp	Rpm	Bhp	Rpm	Bhp	Rpm	Bhp
6,500	B 1004	4.11	1050	4.55	1098	5.04	C 1145	5.57	1192	6.14
7,000	1041	4.73	C 1083	5.15	C 1126	5.62	C 1170	6.14	D 1214	6.70
7,500	C 1081	5.44	1120	5.86	1159	6.32	1199	6.82	1240	7.36
8,000	1124	6.26	1160	6.68	1196	7.13	D 1233	7.62	1270	8.15
8,500	1168	7.17	1202	7.60	D 1235	8.06	1269	8.54	<b>1304</b>	<b>9.05</b>
9,000	D 1214	8.20	D 1245	8.64	1277	9.10	<b>1309</b>	<b>9.58</b>	<b>1341</b>	<b>10.09</b>
9,500	1260	9.33	1290	9.79	<b>1320</b>	<b>10.25</b>	<b>1351</b>	<b>10.74</b>	<b>1381</b>	<b>11.25</b>
10,000	<b>1308</b>	<b>10.58</b>	<b>1337</b>	<b>11.05</b>	<b>1365</b>	<b>11.53</b>	<b>1394</b>	<b>12.03</b>	—	—
10,500	<b>1356</b>	<b>11.95</b>	<b>1384</b>	<b>12.44</b>	—	—	—	—	—	—
11,000	—	—	—	—	—	—	—	—	—	—
11,500	—	—	—	—	—	—	—	—	—	—
12,000	—	—	—	—	—	—	—	—	—	—
12,500	—	—	—	—	—	—	—	—	—	—

LEGEND

**Bhp** — Brake Horsepower Input to Fan

**Boldface** indicates field-supplied motor/drive required.

NOTES:

1. Motor drive ranges:

- (A) Low Range: 687-873 rpm, 5.75 bhp
- (B) Mid-Low Range: 805-1007 rpm, 5.75 bhp
- (C) Mid-High Range: 941-1176 rpm, 8.63 bhp
- (D) High Range: 1014-1297 rpm, 11.50 bhp

All other rpms require field-supplied motor or drive.

2. See page 36 for general fan performance notes.

**Table 14 — Fan Performance — 48PGD20 — Horizontal Supply and Return Units**

AIRFLOW (Cfm)	AVAILABLE EXTERNAL STATIC PRESSURE (in. wg)									
	0.2		0.4		0.6		0.8		1.0	
	Rpm	Bhp	Rpm	Bhp	Rpm	Bhp	Rpm	Bhp	Rpm	Bhp
5000	<b>862</b>	<b>2.65</b>	917	2.93	<b>F</b> 969	3.21	<b>F</b> 1019	3.17	<b>F</b> 1066	3.52
5500	<b>F</b> 937	3.26	<b>F</b> 988	3.56	1036	3.53	<b>F</b> 1083	3.90	<b>G</b> 1127	4.28
6000	1013	3.58	1060	3.96	1105	4.35	1149	4.75	<b>G</b> 1191	5.16
6500	<b>1089</b>	<b>4.48</b>	<b>G</b> 1133	4.89	<b>G</b> 1175	<b>5.31</b>	<b>G</b> 1216	5.73	<b>H</b> 1256	6.17
7000	<b>G</b> 1166	5.52	<b>H</b> 1207	5.96	<b>H</b> 1247	6.41	<b>H</b> 1285	6.86	<b>H</b> 1323	7.32
7500	<b>H</b> 1243	6.71	1282	7.18	<b>H</b> 1319	7.66	<b>1355</b>	<b>8.14</b>	<b>1391</b>	<b>8.63</b>
8000	1320	8.07	<b>1356</b>	<b>8.57</b>	<b>1392</b>	<b>9.08</b>	—	—	—	—
8500	<b>1398</b>	<b>9.60</b>	—	—	—	—	—	—	—	—
9000	—	—	—	—	—	—	—	—	—	—

AIRFLOW (Cfm)	AVAILABLE EXTERNAL STATIC PRESSURE (in. wg)									
	1.2		1.4		1.6		1.8		2.0	
	Rpm	Bhp	Rpm	Bhp	Rpm	Bhp	Rpm	Bhp	Rpm	Bhp
5000	<b>F</b> 1112	3.88	<b>F</b> 1156	4.25	<b>G</b> 1199	4.63	<b>G</b> 1240	5.02	<b>G</b> 1280	5.42
5500	<b>G</b> 1171	4.67	<b>G</b> 1212	5.06	1253	5.47	<b>H</b> 1292	5.88	<b>H</b> 1331	6.30
6000	1232	5.57	<b>H</b> 1271	6.00	<b>H</b> 1310	6.43	<b>1348</b>	<b>6.87</b>	<b>1384</b>	<b>7.31</b>
6500	<b>H</b> 1295	6.61	1333	7.06	<b>1369</b>	<b>7.52</b>	—	—	—	—
7000	<b>1360</b>	<b>7.80</b>	<b>1396</b>	<b>8.27</b>	—	—	—	—	—	—
7500	—	—	—	—	—	—	—	—	—	—
8000	—	—	—	—	—	—	—	—	—	—
8500	—	—	—	—	—	—	—	—	—	—
9000	—	—	—	—	—	—	—	—	—	—

LEGEND

**Bhp** — Brake Horsepower Input to Fan

**Boldface** indicates field-supplied motor/drive required.

NOTES:

- Motor drive ranges:  
 (E) Low Range: Not Used  
 (F) Mid-Low Range: 896-1227 rpm, 4.26 bhp (208/230 and 460-v), 873-1108 rpm, 5.75 bhp (575-v)  
 (G) Mid-High Range: 1113-1414 rpm, 5.75 bhp  
 (H) High Range: 1096-1339 rpm, 8.63 bhp

All other rpms require field-supplied motor or drive.

- See page 36 for general fan performance notes.

**Table 15 — Fan Performance — 48PGE20 — Horizontal Supply and Return Units**

AIRFLOW (Cfm)	AVAILABLE EXTERNAL STATIC PRESSURE (in. wg)									
	0.2		0.4		0.6		0.8		1.0	
	Rpm	Bhp	Rpm	Bhp	Rpm	Bhp	Rpm	Bhp	Rpm	Bhp
5000	<b>875</b>	<b>2.74</b>	931	3.04	<b>F</b> 984	3.34	<b>F</b> 1035	3.33	<b>F</b> 1083	3.69
5500	<b>F</b> 952	3.38	<b>F</b> 1003	3.32	1053	3.70	1100	4.09	<b>G</b> 1145	4.49
6000	1029	3.74	1077	4.15	<b>G</b> 1123	4.56	<b>G</b> 1167	4.98	<b>G</b> 1210	5.41
6500	<b>1106</b>	<b>4.67</b>	<b>G</b> 1151	5.11	<b>G</b> 1194	5.56	<b>H</b> 1236	6.01	<b>H</b> 1276	6.47
7000	<b>G</b> 1184	5.75	<b>H</b> 1226	6.23	<b>H</b> 1266	6.71	<b>H</b> 1306	7.19	<b>1344</b>	<b>7.68</b>
7500	<b>H</b> 1262	7.00	1302	7.50	<b>1340</b>	<b>8.01</b>	<b>1377</b>	<b>8.53</b>	—	—
8000	<b>1341</b>	<b>8.41</b>	<b>1378</b>	<b>8.95</b>	—	—	—	—	—	—
8500	—	—	—	—	—	—	—	—	—	—
9000	—	—	—	—	—	—	—	—	—	—

AIRFLOW (Cfm)	AVAILABLE EXTERNAL STATIC PRESSURE (in. wg)									
	1.2		1.4		1.6		1.8		2.0	
	Rpm	Bhp	Rpm	Bhp	Rpm	Bhp	Rpm	Bhp	Rpm	Bhp
5000	<b>F</b> 1130	4.07	<b>G</b> 1174	4.45	<b>G</b> 1218	4.84	<b>G</b> 1259	5.23	<b>G</b> 1300	5.63
5500	<b>G</b> 1189	4.90	1232	5.31	1273	5.72	<b>H</b> 1313	6.15	<b>1352</b>	<b>6.58</b>
6000	<b>H</b> 1251	5.85	<b>H</b> 1292	6.29	<b>H</b> 1331	6.74	<b>1369</b>	<b>7.19</b>	—	—
6500	1315	6.94	<b>1354</b>	<b>7.41</b>	<b>1391</b>	<b>7.89</b>	—	—	—	—
7000	<b>1381</b>	<b>8.18</b>	—	—	—	—	—	—	—	—
7500	—	—	—	—	—	—	—	—	—	—
8000	—	—	—	—	—	—	—	—	—	—
8500	—	—	—	—	—	—	—	—	—	—
9000	—	—	—	—	—	—	—	—	—	—

LEGEND

**Bhp** — Brake Horsepower Input to Fan

**Boldface** indicates field-supplied motor/drive required.

NOTES:

- Motor drive ranges:  
 (E) Low Range: Not Used  
 (F) Mid-Low Range: 896-1227 rpm, 4.26 bhp (208/230 and 460-v), 873-1108 rpm, 5.75 bhp (575-v)  
 (G) Mid-High Range: 1113-1414 rpm, 5.75 bhp  
 (H) High Range: 1096-1339 rpm, 8.63 bhp  
 All other rpms require field-supplied motor or drive.
- See page 36 for general fan performance notes.

**Table 16 — Fan Performance — 48PGF20 — Horizontal Supply and Return Units**

AIRFLOW (Cfm)	AVAILABLE EXTERNAL STATIC PRESSURE (in. wg)									
	0.2		0.4		0.6		0.8		1.0	
	Rpm	Bhp	Rpm	Bhp	Rpm	Bhp	Rpm	Bhp	Rpm	Bhp
5000	<b>875</b>	<b>2.74</b>	931	3.04	F 984	3.34	F 1035	3.33	F 1083	3.69
5500	F 952	3.38	F 1003	3.32	1053	3.70	1100	4.09	G 1145	4.49
6000	1029	3.74	1077	4.15	G 1123	4.56	G 1167	4.98	G 1210	5.41
6500	<b>1106</b>	<b>4.67</b>	G 1151	5.11	G 1194	5.56	H 1236	6.01	H 1276	6.47
7000	G 1184	5.75	H 1226	6.23	H 1266	6.71	H 1306	7.19	<b>1344</b>	<b>7.68</b>
7500	H 1262	7.00	H 1302	7.50	<b>1340</b>	<b>8.01</b>	<b>1377</b>	<b>8.53</b>	—	—
8000	<b>1341</b>	<b>8.41</b>	<b>1378</b>	<b>8.95</b>	—	—	—	—	—	—
8500	—	—	—	—	—	—	—	—	—	—
9000	—	—	—	—	—	—	—	—	—	—

AIRFLOW (Cfm)	AVAILABLE EXTERNAL STATIC PRESSURE (in. wg)									
	1.2		1.4		1.6		1.8		2.0	
	Rpm	Bhp	Rpm	Bhp	Rpm	Bhp	Rpm	Bhp	Rpm	Bhp
5000	F 1130	4.07	G 1174	4.45	G 1218	4.84	G 1259	5.23	G 1300	5.63
5500	G 1189	4.90	1232	5.31	1273	5.72	H 1313	6.15	<b>1352</b>	<b>6.58</b>
6000	H 1251	5.85	H 1292	6.29	H 1331	6.74	<b>1369</b>	<b>7.19</b>	—	—
6500	1315	6.94	<b>1354</b>	<b>7.41</b>	<b>1391</b>	<b>7.89</b>	—	—	—	—
7000	<b>1381</b>	<b>8.18</b>	—	—	—	—	—	—	—	—
7500	—	—	—	—	—	—	—	—	—	—
8000	—	—	—	—	—	—	—	—	—	—
8500	—	—	—	—	—	—	—	—	—	—
9000	—	—	—	—	—	—	—	—	—	—

LEGEND

**Bhp** — Brake Horsepower Input to Fan

**Boldface** indicates field-supplied motor/drive required.

NOTES:

- Motor drive ranges:  
 (E) Low Range: Not Used  
 (F) Mid-Low Range: 896-1227 rpm, 4.26 bhp (208/230 and 460-v), 873-1108 rpm, 5.75 bhp (575-v)  
 (G) Mid-High Range: 1113-1414 rpm, 5.75 bhp  
 (H) High Range: 1096-1339 rpm, 8.63 bhp

All other rpms require field-supplied motor or drive.

- See page 36 for general fan performance notes.

**Table 17 — Fan Performance — 48PGD24 — Horizontal Supply and Return Units**

AIRFLOW (Cfm)	AVAILABLE EXTERNAL STATIC PRESSURE (in. wg)									
	0.2		0.4		0.6		0.8		1.0	
	Rpm	Bhp	Rpm	Bhp	Rpm	Bhp	Rpm	Bhp	Rpm	Bhp
5,500	F 937	3.26	F 988	3.56	F 1036	3.53	F 1083	3.90	G 1127	4.28
6,000	1013	3.58	F 1060	3.96	<b>1105</b>	<b>4.35</b>	G 1149	4.75	G 1191	5.16
6,500	<b>1089</b>	<b>4.48</b>	G 1133	4.89	G 1175	5.31	G 1216	5.73	H 1256	6.17
7,000	G 1166	5.52	H 1207	5.96	H 1247	6.41	H 1285	6.86	H 1323	7.32
7,500	H 1243	6.71	H 1282	7.18	H 1319	7.66	<b>1355</b>	<b>8.14</b>	<b>1391</b>	<b>8.63</b>
8,000	1320	8.07	<b>1356</b>	<b>8.57</b>	<b>1392</b>	<b>9.08</b>	—	—	—	—
8,500	<b>1398</b>	<b>9.60</b>	—	—	—	—	—	—	—	—
9,000	—	—	—	—	—	—	—	—	—	—
9,500	—	—	—	—	—	—	—	—	—	—
10,000	—	—	—	—	—	—	—	—	—	—

AIRFLOW (Cfm)	AVAILABLE EXTERNAL STATIC PRESSURE (in. wg)									
	1.2		1.4		1.6		1.8		2.0	
	Rpm	Bhp	Rpm	Bhp	Rpm	Bhp	Rpm	Bhp	Rpm	Bhp
5,500	G 1171	4.67	G 1212	5.06	G 1253	5.47	H 1292	5.88	1331	6.30
6,000	1232	5.57	H 1271	6.00	H 1310	6.43	<b>1348</b>	<b>6.87</b>	<b>1384</b>	<b>7.31</b>
6,500	H 1295	6.61	H 1333	7.06	<b>1369</b>	<b>7.52</b>	—	—	—	—
7,000	<b>1360</b>	<b>7.80</b>	<b>1396</b>	<b>8.27</b>	—	—	—	—	—	—
7,500	—	—	—	—	—	—	—	—	—	—
8,000	—	—	—	—	—	—	—	—	—	—
8,500	—	—	—	—	—	—	—	—	—	—
9,000	—	—	—	—	—	—	—	—	—	—
9,500	—	—	—	—	—	—	—	—	—	—
10,000	—	—	—	—	—	—	—	—	—	—

LEGEND

**Bhp** — Brake Horsepower Input to Fan

**Boldface** indicates field-supplied motor/drive required.

NOTES:

- Motor drive ranges:  
 (E) Low Range: Not Used  
 (F) Mid-Low Range: 896-1227 rpm, 4.26 bhp (208/230 and 460-v), 873-1108 rpm, 5.75 bhp (575-v)  
 (G) Mid-High Range: 1113-1414 rpm, 5.75 bhp  
 (H) High Range: 1096-1339 rpm, 8.63 bhp  
 All other rpms require field-supplied motor or drive.
- See page 36 for general fan performance notes.

**Table 18 — Fan Performance — 48PGE24 — Horizontal Supply and Return Units**

AIRFLOW (Cfm)	AVAILABLE EXTERNAL STATIC PRESSURE (in. wg)									
	0.2		0.4		0.6		0.8		1.0	
	Rpm	Bhp	Rpm	Bhp	Rpm	Bhp	Rpm	Bhp	Rpm	Bhp
5,500	<b>F</b> 952	3.38	<b>F</b> 1003	3.32	<b>F</b> 1053	3.70	<b>F</b> 1100	4.09	<b>G</b> 1145	4.49
6,000	1029	3.74	1077	4.15	<b>G</b> 1123	4.56	<b>G</b> 1167	4.98	1210	5.41
6,500	<b>1106</b>	<b>4.67</b>	<b>G</b> 1151	5.11	<b>G</b> 1194	5.56	1236	6.01	<b>H</b> 1276	6.47
7,000	<b>G</b> 1184	5.75	<b>H</b> 1226	6.23	<b>H</b> 1266	6.71	<b>H</b> 1306	7.19	<b>1344</b>	<b>7.68</b>
7,500	<b>H</b> 1262	7.00	<b>H</b> 1302	7.50	<b>1340</b>	<b>8.01</b>	<b>1377</b>	<b>8.53</b>	—	—
8,000	<b>1341</b>	<b>8.41</b>	<b>1378</b>	<b>8.95</b>	—	—	—	—	—	—
8,500	—	—	—	—	—	—	—	—	—	—
9,000	—	—	—	—	—	—	—	—	—	—
9,500	—	—	—	—	—	—	—	—	—	—
10,000	—	—	—	—	—	—	—	—	—	—

AIRFLOW (Cfm)	AVAILABLE EXTERNAL STATIC PRESSURE (in. wg)									
	1.2		1.4		1.6		1.8		2.0	
	Rpm	Bhp	Rpm	Bhp	Rpm	Bhp	Rpm	Bhp	Rpm	Bhp
5,500	<b>G</b> 1189	4.90	<b>G</b> 1232	5.31	<b>G</b> 1273	5.72	<b>H</b> 1313	6.15	<b>1352</b>	<b>6.58</b>
6,000	<b>H</b> 1251	5.85	<b>H</b> 1292	6.29	<b>H</b> 1331	6.74	<b>1369</b>	<b>7.19</b>	—	—
6,500	1315	6.94	<b>1354</b>	<b>7.41</b>	<b>1391</b>	<b>7.89</b>	—	—	—	—
7,000	<b>1381</b>	<b>8.18</b>	—	—	—	—	—	—	—	—
7,500	—	—	—	—	—	—	—	—	—	—
8,000	—	—	—	—	—	—	—	—	—	—
8,500	—	—	—	—	—	—	—	—	—	—
9,000	—	—	—	—	—	—	—	—	—	—
9,500	—	—	—	—	—	—	—	—	—	—
10,000	—	—	—	—	—	—	—	—	—	—

LEGEND

**Bhp** — Brake Horsepower Input to Fan

**Boldface** indicates field-supplied motor/drive required.

NOTES:

- Motor drive ranges:  
 (E) Low Range: Not Used  
 (F) Mid-Low Range: 896-1227 rpm, 4.26 bhp (208/230 and 460-v), 873-1108 rpm, 5.75 bhp (575-v)  
 (G) Mid-High Range: 1113-1414 rpm, 5.75 bhp  
 (H) High Range: 1096-1339 rpm, 8.63 bhp  
 All other rpms require field-supplied motor or drive.
- See page 36 for general fan performance notes.



**Table 19 — Fan Performance — 48PGF24 — Horizontal Supply and Return Units**

AIRFLOW (Cfm)	AVAILABLE EXTERNAL STATIC PRESSURE (in. wg)									
	0.2		0.4		0.6		0.8		1.0	
	Rpm	Bhp	Rpm	Bhp	Rpm	Bhp	Rpm	Bhp	Rpm	Bhp
5,500	<b>F</b> 952	3.38	<b>F</b> 1003	3.32	<b>F</b> 1053	3.70	<b>F</b> 1100	4.09	<b>G</b> 1145	4.49
6,000	1029	3.74	1077	4.15	<b>G</b> 1123	4.56	<b>G</b> 1167	4.98	1210	5.41
6,500	<b>1106</b>	<b>4.67</b>	<b>G</b> 1151	5.11	<b>G</b> 1194	5.56	<b>H</b> 1236	6.01	<b>H</b> 1276	6.47
7,000	<b>G</b> 1184	5.75	<b>H</b> 1226	6.23	<b>H</b> 1266	6.71	<b>H</b> 1306	7.19	<b>1344</b>	<b>7.68</b>
7,500	<b>H</b> 1262	7.00	<b>H</b> 1302	7.50	<b>1340</b>	<b>8.01</b>	<b>1377</b>	<b>8.53</b>	—	—
8,000	<b>1341</b>	<b>8.41</b>	<b>1378</b>	<b>8.95</b>	—	—	—	—	—	—
8,500	—	—	—	—	—	—	—	—	—	—
9,000	—	—	—	—	—	—	—	—	—	—
9,500	—	—	—	—	—	—	—	—	—	—
10,000	—	—	—	—	—	—	—	—	—	—

AIRFLOW (Cfm)	AVAILABLE EXTERNAL STATIC PRESSURE (in. wg)									
	1.2		1.4		1.6		1.8		2.0	
	Rpm	Bhp	Rpm	Bhp	Rpm	Bhp	Rpm	Bhp	Rpm	Bhp
5,500	<b>G</b> 1189	4.90	<b>G</b> 1232	5.31	<b>G</b> 1273	5.72	<b>H</b> 1313	6.15	<b>1352</b>	<b>6.58</b>
6,000	<b>H</b> 1251	5.85	<b>H</b> 1292	6.29	<b>H</b> 1331	6.74	<b>1369</b>	<b>7.19</b>	—	—
6,500	1315	6.94	<b>1354</b>	<b>7.41</b>	<b>1391</b>	<b>7.89</b>	—	—	—	—
7,000	<b>1381</b>	<b>8.18</b>	—	—	—	—	—	—	—	—
7,500	—	—	—	—	—	—	—	—	—	—
8,000	—	—	—	—	—	—	—	—	—	—
8,500	—	—	—	—	—	—	—	—	—	—
9,000	—	—	—	—	—	—	—	—	—	—
9,500	—	—	—	—	—	—	—	—	—	—
10,000	—	—	—	—	—	—	—	—	—	—

LEGEND

**Bhp** — Brake Horsepower Input to Fan

**Boldface** indicates field-supplied motor/drive required.

NOTES:

1. Motor drive ranges:

(E) Low Range: Not Used

(F) Mid-Low Range: 896-1227 rpm, 4.26 bhp (208/230 and 460-v), 873-1108 rpm, 5.75 bhp (575-v)

(G) Mid-High Range: 1113-1414 rpm, 5.75 bhp

(H) High Range: 1096-1339 rpm, 8.63 bhp

All other rpms require field-supplied motor or drive.

2. See page 36 for general fan performance notes.

**Table 20 — Fan Performance — 48PGD28 — Horizontal Supply and Return Units**

AIRFLOW (Cfm)	AVAILABLE EXTERNAL STATIC PRESSURE (in. wg)									
	0.2		0.4		0.6		0.8		1.0	
	Rpm	Bhp	Rpm	Bhp	Rpm	Bhp	Rpm	Bhp	Rpm	Bhp
6,500	<b>E</b> 786	2.50	<b>E</b> 819	2.70	<b>E</b> 857	2.96	899	3.25	<b>F</b> 943	3.59
7,000	842	3.09	871	3.30	905	3.55	<b>F</b> 943	3.85	<b>F</b> 983	4.19
7,500	<b>F</b> 898	3.77	<b>F</b> 925	3.99	<b>F</b> 955	4.24	989	4.54	1026	4.88
8,000	955	4.55	979	4.77	1007	5.03	1037	5.33	<b>G</b> 1070	5.67
8,500	1012	5.42	1034	5.65	1059	5.92	<b>G</b> 1087	6.22	<b>G</b> 1117	6.56
9,000	<b>G</b> 1069	6.41	<b>G</b> 1090	6.65	<b>G</b> 1113	6.92	1138	7.23	1165	7.57
9,500	1127	7.51	1146	7.76	1167	8.04	1190	8.35	<b>H</b> 1215	8.69
10,000	<b>H</b> 1184	8.74	<b>H</b> 1202	8.99	<b>H</b> 1221	9.28	<b>H</b> 1243	9.59	<b>H</b> 1266	9.93
10,500	1242	10.09	1258	10.35	1276	10.64	1296	10.96	<b>1318</b>	<b>11.31</b>
11,000	<b>1299</b>	<b>11.58</b>	<b>1315</b>	<b>11.85</b>	<b>1332</b>	<b>12.15</b>	<b>1350</b>	<b>12.47</b>	<b>1370</b>	<b>12.82</b>
11,500	<b>1357</b>	<b>13.20</b>	<b>1372</b>	<b>13.48</b>	<b>1388</b>	<b>13.79</b>	—	—	—	—
12,000	—	—	—	—	—	—	—	—	—	—
12,500	—	—	—	—	—	—	—	—	—	—

AIRFLOW (Cfm)	AVAILABLE EXTERNAL STATIC PRESSURE (in. wg)									
	1.2		1.4		1.6		1.8		2.0	
	Rpm	Bhp	Rpm	Bhp	Rpm	Bhp	Rpm	Bhp	Rpm	Bhp
6,500	<b>F</b> 988	3.97	1035	4.39	1082	4.87	<b>G</b> 1129	5.39	1177	5.95
7,000	1024	4.57	<b>G</b> 1066	4.98	<b>G</b> 1109	5.43	<b>G</b> 1153	5.93	1197	6.48
7,500	<b>G</b> 1063	5.25	1102	5.66	1141	6.11	1181	6.59	<b>H</b> 1221	7.11
8,000	1105	6.04	1140	6.45	1176	6.89	<b>H</b> 1213	7.36	1250	7.87
8,500	1149	6.94	1181	7.34	1215	7.78	1249	8.25	1283	8.74
9,000	1194	7.94	<b>H</b> 1225	8.35	<b>H</b> 1256	8.79	1287	9.25	<b>1319</b>	<b>9.74</b>
9,500	<b>H</b> 1242	9.07	1270	9.47	1298	9.91	<b>1328</b>	<b>10.37</b>	<b>1358</b>	<b>10.87</b>
10,000	1290	10.31	<b>1316</b>	<b>10.72</b>	<b>1343</b>	<b>11.16</b>	<b>1370</b>	<b>11.62</b>	<b>1399</b>	<b>12.11</b>
10,500	<b>1340</b>	<b>11.69</b>	<b>1364</b>	<b>12.10</b>	<b>1389</b>	<b>12.54</b>	—	—	—	—
11,000	<b>1391</b>	<b>13.20</b>	—	—	—	—	—	—	—	—
11,500	—	—	—	—	—	—	—	—	—	—
12,000	—	—	—	—	—	—	—	—	—	—
12,500	—	—	—	—	—	—	—	—	—	—

LEGEND

**Bhp** — Brake Horsepower Input to Fan

**Boldface** indicates field-supplied motor/drive required.

NOTES:

1. Motor drive ranges:

- (E) Low Range: 687-873 rpm, 5.75 bhp
- (F) Mid-Low Range: 805-1007 rpm, 5.75 bhp
- (G) Mid-High Range: 941-1176 rpm, 8.63 bhp
- (H) High Range: 1014-1297 rpm, 11.50 bhp

All other rpms require field-supplied motor or drive.

2. See page 36 for general fan performance notes.

**Table 21 — Fan Performance — 48PGE28 — Horizontal Supply and Return Units**

AIRFLOW (Cfm)	AVAILABLE EXTERNAL STATIC PRESSURE (in. wg)									
	0.2		0.4		0.6		0.8		1.0	
	Rpm	Bhp	Rpm	Bhp	Rpm	Bhp	Rpm	Bhp	Rpm	Bhp
6,500	<b>E</b> 799	2.58	<b>E</b> 833	2.79	<b>E</b> 872	3.05	914	3.36	<b>F</b> 958	3.71
7,000	856	3.19	887	3.41	<b>F</b> 921	3.67	<b>F</b> 958	3.98	999	4.33
7,500	<b>F</b> 913	3.89	<b>F</b> 941	4.12	972	4.39	1006	4.69	1042	5.04
8,000	971	4.69	996	4.93	1024	5.20	1055	5.51	<b>G</b> 1088	5.86
8,500	1029	5.60	1052	5.85	<b>G</b> 1078	6.12	<b>G</b> 1106	6.44	1136	6.78
9,000	<b>G</b> 1087	6.62	<b>G</b> 1108	6.87	1132	7.16	1158	7.47	1185	7.82
9,500	1145	7.75	1165	8.02	1187	8.31	1211	8.63	<b>H</b> 1236	8.99
10,000	<b>H</b> 1203	9.01	<b>H</b> 1222	9.29	<b>H</b> 1243	9.59	<b>H</b> 1265	9.92	1288	10.28
10,500	1261	10.40	1279	10.69	<b>1299</b>	<b>11.00</b>	<b>1319</b>	<b>11.34</b>	<b>1341</b>	<b>11.70</b>
11,000	<b>1320</b>	<b>11.93</b>	<b>1337</b>	<b>12.23</b>	<b>1355</b>	<b>12.55</b>	<b>1374</b>	<b>12.89</b>	<b>1394</b>	<b>13.26</b>
11,500	<b>1378</b>	<b>13.61</b>	—	—	—	—	—	—	—	—
12,000	—	—	—	—	—	—	—	—	—	—
12,500	—	—	—	—	—	—	—	—	—	—

AIRFLOW (Cfm)	AVAILABLE EXTERNAL STATIC PRESSURE (in. wg)									
	1.2		1.4		1.6		1.8		2.0	
	Rpm	Bhp	Rpm	Bhp	Rpm	Bhp	Rpm	Bhp	Rpm	Bhp
6,500	<b>F</b> 1005	4.12	1052	4.57	1100	5.06	<b>G</b> 1148	5.60	1195	6.17
7,000	1041	4.72	1084	5.16	<b>G</b> 1128	5.64	<b>G</b> 1172	6.17	<b>H</b> 1217	6.74
7,500	<b>G</b> 1080	5.43	1119	5.86	1160	6.33	1201	6.84	1242	7.40
8,000	1122	6.24	1158	6.66	1195	7.13	<b>H</b> 1233	7.63	1272	8.17
8,500	1167	7.16	1200	7.58	<b>H</b> 1234	8.04	1269	8.53	<b>1304</b>	<b>9.06</b>
9,000	1214	8.21	<b>H</b> 1244	8.62	1275	9.07	<b>1308</b>	<b>9.56</b>	<b>1340</b>	<b>10.08</b>
9,500	<b>H</b> 1262	9.37	1290	9.78	<b>1319</b>	<b>10.23</b>	<b>1349</b>	<b>10.71</b>	<b>1379</b>	<b>11.23</b>
10,000	<b>1312</b>	<b>10.66</b>	<b>1338</b>	<b>11.08</b>	<b>1365</b>	<b>11.52</b>	<b>1392</b>	<b>12.00</b>	—	—
10,500	<b>1363</b>	<b>12.09</b>	<b>1387</b>	<b>12.51</b>	—	—	—	—	—	—
11,000	—	—	—	—	—	—	—	—	—	—
11,500	—	—	—	—	—	—	—	—	—	—
12,000	—	—	—	—	—	—	—	—	—	—
12,500	—	—	—	—	—	—	—	—	—	—

LEGEND

**Bhp** — Brake Horsepower Input to Fan

**Boldface** indicates field-supplied motor/drive required.

NOTES:

1. Motor drive ranges:

(E) Low Range: 687-873 rpm, 5.75 bhp

(F) Mid-Low Range: 805-1007 rpm, 5.75 bhp

(G) Mid-High Range: 941-1176 rpm, 8.63 bhp

(H) High Range: 1014-1297 rpm, 11.50 bhp

All other rpms require field-supplied motor or drive.

2. See page 36 for general fan performance notes.

**Table 22 — Fan Performance — 48PGF28 — Horizontal Supply and Return Units**

AIRFLOW (Cfm)	AVAILABLE EXTERNAL STATIC PRESSURE (in. wg)									
	0.2		0.4		0.6		0.8		1.0	
	Rpm	Bhp	Rpm	Bhp	Rpm	Bhp	Rpm	Bhp	Rpm	Bhp
6,500	E 799	2.58	E 833	2.79	E 872	3.05	914	3.36	F 958	3.71
7,000	856	3.19	887	3.41	921	3.67	F 958	3.98	999	4.33
7,500	F 913	3.89	F 941	4.12	F 972	4.39	1006	4.69	1042	5.04
8,000	971	4.69	996	4.93	1024	5.20	1055	5.51	G 1088	5.86
8,500	1029	5.60	1052	5.85	G 1078	6.12	G 1106	6.44	1136	6.78
9,000	G 1087	6.62	G 1108	6.87	1132	7.16	1158	7.47	1185	7.82
9,500	1145	7.75	1165	8.02	1187	8.31	H 1211	8.63	H 1236	8.99
10,000	H 1203	9.01	H 1222	9.29	H 1243	9.59	H 1265	9.92	1288	10.28
10,500	1261	10.40	H 1279	10.69	<b>1299</b>	<b>11.00</b>	<b>1319</b>	<b>11.34</b>	<b>1341</b>	<b>11.70</b>
11,000	<b>1320</b>	<b>11.93</b>	<b>1337</b>	<b>12.23</b>	<b>1355</b>	<b>12.55</b>	<b>1374</b>	<b>12.89</b>	<b>1394</b>	<b>13.26</b>
11,500	<b>1378</b>	<b>13.61</b>	—	—	—	—	—	—	—	—
12,000	—	—	—	—	—	—	—	—	—	—
12,500	—	—	—	—	—	—	—	—	—	—

AIRFLOW (Cfm)	AVAILABLE EXTERNAL STATIC PRESSURE (in. wg)									
	1.2		1.4		1.6		1.8		2.0	
	Rpm	Bhp	Rpm	Bhp	Rpm	Bhp	Rpm	Bhp	Rpm	Bhp
6,500	F 1005	4.12	1052	4.57	1100	5.06	G 1148	5.60	1195	6.17
7,000	1041	4.72	G 1084	5.16	G 1128	5.64	1172	6.17	H 1217	6.74
7,500	G 1080	5.43	1119	5.86	1160	6.33	1201	6.84	1242	7.40
8,000	1122	6.24	1158	6.66	1195	7.13	H 1233	7.63	1272	8.17
8,500	1167	7.16	1200	7.58	H 1234	8.04	1269	8.53	<b>1304</b>	<b>9.06</b>
9,000	H 1214	8.21	H 1244	8.62	1275	9.07	<b>1308</b>	<b>9.56</b>	<b>1340</b>	<b>10.08</b>
9,500	1262	9.37	1290	9.78	<b>1319</b>	<b>10.23</b>	<b>1349</b>	<b>10.71</b>	<b>1379</b>	<b>11.23</b>
10,000	<b>1312</b>	<b>10.66</b>	<b>1338</b>	<b>11.08</b>	<b>1365</b>	<b>11.52</b>	<b>1392</b>	<b>12.00</b>	—	—
10,500	<b>1363</b>	<b>12.09</b>	<b>1387</b>	<b>12.51</b>	—	—	—	—	—	—
11,000	—	—	—	—	—	—	—	—	—	—
11,500	—	—	—	—	—	—	—	—	—	—
12,000	—	—	—	—	—	—	—	—	—	—
12,500	—	—	—	—	—	—	—	—	—	—

LEGEND

**Bhp** — Brake Horsepower Input to Fan

**Boldface** indicates field-supplied motor/drive required.

NOTES:

- Motor drive ranges:  
 (E) Low Range: 687-873 rpm, 5.75 bhp  
 (F) Mid-Low Range: 805-1007 rpm, 5.75 bhp  
 (G) Mid-High Range: 941-1176 rpm, 8.63 bhp  
 (H) High Range: 1014-1297 rpm, 11.50 bhp  
 All other rpms require field-supplied motor or drive.
- See below for general fan performance notes.

**GENERAL NOTES FOR FAN PERFORMANCE DATA TABLES**

- Static pressure losses (i.e., economizer, electric heat, etc.) must be added to external static pressure before entering Fan Performance table.
- Interpolation is permissible. Do not extrapolate.
- Fan performance is based on wet coils, clean filters, and casing losses. See Accessory/FIOP Static Pressure information on page 39.
- Extensive motor and drive testing on these units ensures that the full horsepower range of the motor can be utilized with confidence. Using the fan motors up to the bhp rating shown will not result in nuisance tripping or premature motor failure. Unit warranty will not be affected.
- Use of a field-supplied motor may affect wire size. Recalculate the unit power supply MCA and MOCF if required. Contact the local Carrier representative for details.
- Use the following formula to calculate Input Watts:  
 Input Watts = Bhp x (746/motor eff.)

**Table 23 — Power Exhaust Fan Performance — 48PG20-28**

AIRFLOW (Cfm)	LOW SPEED						MEDIUM SPEED						HIGH SPEED					
	208 V			230,460,575V			208 V			230,460,575V			208 V			230,460,575V		
	ESP	Bhp	Watts	ESP	Bhp	Watts	ESP	Bhp	Watts	ESP	Bhp	Watts	ESP	Bhp	Watts	ESP	Bhp	Watts
3250	0.32	1.41	1580	0.70	1.49	1670	—	—	—	—	—	—	—	—	—	—	—	—
3350	0.23	1.44	1610	0.63	1.52	1700	0.60	1.51	1690	0.82	1.62	1810	—	—	—	—	—	—
3450	0.17	1.46	1635	0.59	1.55	1730	0.55	1.54	1720	0.78	1.64	1840	—	—	—	—	—	—
3550	0.13	1.47	1645	0.56	1.56	1745	0.49	1.56	1750	0.73	1.67	1870	—	—	—	—	—	—
3650	0.09	1.49	1665	0.53	1.58	1765	0.43	1.59	1780	0.68	1.70	1900	—	—	—	—	—	—
3750	—	—	—	0.51	1.60	1790	0.39	1.62	1815	0.64	1.72	1930	—	—	—	—	—	—
3850	—	—	—	0.48	1.62	1810	0.33	1.64	1835	0.59	1.74	1950	0.60	1.85	2070	0.73	1.99	2230
3950	—	—	—	0.45	1.64	1835	0.27	1.66	1860	0.54	1.76	1975	0.56	1.87	2095	0.69	2.01	2255
4050	—	—	—	0.40	1.67	1865	0.22	1.68	1885	0.49	1.79	2000	0.51	1.89	2120	0.65	2.04	2280
4250	—	—	—	—	—	—	0.17	1.74	1945	0.40	1.84	2060	0.41	1.92	2145	0.56	2.06	2310
4450	—	—	—	—	—	—	0.00	1.79	2005	0.30	1.89	2115	0.31	1.97	2205	0.47	2.12	2370
4650	—	—	—	—	—	—	—	—	—	0.22	1.94	2170	0.20	2.04	2280	0.37	2.19	2450
4850	—	—	—	—	—	—	—	—	—	0.16	1.98	2215	0.11	2.09	2335	0.30	2.24	2505
5050	—	—	—	—	—	—	—	—	—	0.12	2.02	2260	0.04	2.13	2385	0.23	2.28	2555
5250	—	—	—	—	—	—	—	—	—	—	—	—	—	—	—	0.17	2.33	2610
5450	—	—	—	—	—	—	—	—	—	—	—	—	—	—	—	0.12	2.38	2665
5650	—	—	—	—	—	—	—	—	—	—	—	—	—	—	—	0.07	2.40	2690
5850	—	—	—	—	—	—	—	—	—	—	—	—	—	—	—	0.04	2.42	2710

LEGEND

ESP — External Static Pressure

**Table 24 — Operation Air Quantity Limits**

48PG	COOLING		GAS HEAT	HEATING (NAT. GAS, VERTICAL)	HEATING (NAT. GAS, HORIZONTAL)	HEATING (PROPANE, VERTICAL)	HEATING (PROPANE, HORIZONTAL)
	Minimum Cfm	Maximum Cfm		Minimum Cfm	Minimum Cfm	Minimum Cfm	Minimum Cfm
20	5000	9,000	High Heat (8 Cell)	5522	5522	5522	4920
			Medium Heat (8 Cell)	4977	4977	4480	4480
			Low Heat (5 Cell)	4218	4218	4218	3796
24	5500	10,000	High Heat (8 Cell)	5522	5522	5522	4920
			Medium Heat (8 Cell)	4977	4977	4480	4480
			Low Heat (5 Cell)	4218	4218	4218	3796
28	6500	12,000	High Heat (8 Cell)	5522	5470*	5522	4920*
			Medium Heat (8 Cell)	4977	4977*	4480	4480*
			Low Heat (5 Cell)	4218	4218	4218	3796

\*7000 cfm minimum recommended above 1.0 in. wg external static pressure.

**Table 25 — Evaporator Fan Motor Specifications**

48PG	DRIVE	ORIENTATION	MOTOR P/N	NOMINAL HP	VOLTAGE	MAX WATTS	EFFICIENCY %	MAX BHP	MAX BkW	MAX AMPS
20	Low	Vertical	HD60FK651	3.7	208	3698	85.8	4.25	3.17	10.6
			HD60FK651	3.7	230	3698	85.8	4.25	3.17	9.6
			HD60FK651	3.7	460	3698	85.8	4.25	3.17	4.8
	Mid-Low	Vertical	HD60FK575	5	575	4900	87.5	5.75	4.29	6.1
			HD60FK653	5	208	4900	87.5	5.75	4.29	16.7
			HD60FK653	5	230	4900	87.5	5.75	4.29	15.2
			HD60FK653	5	460	4900	87.5	5.75	4.29	7.6
			HD60FK575	5	575	4900	87.5	5.75	4.29	6.1
			HD62FK652	7.5	208	7267	88.5	8.63	6.43	24.2
	Mid-High	Vertical	HD62FK652	7.5	230	7267	88.5	8.63	6.43	22
			HD62FK652	7.5	460	7267	88.5	8.63	6.43	11
			HD62FK576	7.5	575	7267	88.5	8.63	6.43	9
	High	Vertical	HD64FK651	10	208	9582	89.5	11.5	8.58	30.8
			HD64FK651	10	230	9582	89.5	11.5	8.58	28
			HD64FK651	10	460	9582	89.5	11.5	8.58	14
	Low	Horizontal	HD64FK575	10	575	9582	89.5	11.5	8.58	11
			N/A	N/A	208	N/A	N/A	N/A	N/A	N/A
			N/A	N/A	230	N/A	N/A	N/A	N/A	N/A
			N/A	N/A	460	N/A	N/A	N/A	N/A	N/A
	Mid-Low	Horizontal	N/A	N/A	575	N/A	N/A	N/A	N/A	N/A
			HD60FK651	3.7	208	3698	85.8	4.25	3.17	10.6
			HD60FK651	3.7	230	3698	85.8	4.25	3.17	9.6
			HD60FK651	3.7	460	3698	85.8	4.25	3.17	4.8
	Mid-High	Horizontal	HD60FK575	5	575	4900	87.5	5.75	4.29	6.1
			HD60FK653	5	208	4900	87.5	5.75	4.29	16.7
			HD60FK653	5	230	4900	87.5	5.75	4.29	15.2
	High	Horizontal	HD60FK653	5	460	4900	87.5	5.75	4.29	7.6
			HD60FK575	5	575	4900	87.5	5.75	4.29	6.1
			HD62FK652	7.5	208	7267	88.5	8.63	6.43	24.2
	High	Horizontal	HD62FK652	7.5	230	7267	88.5	8.63	6.43	22
HD62FK652			7.5	460	7267	88.5	8.63	6.43	11	
HD62FK576			7.5	575	7267	88.5	8.63	6.43	9	

**Table 25 — Evaporator Fan Motor Specifications (cont)**

48PG	DRIVE	ORIENTATION	MOTOR P/N	NOMINAL HP	VOLTAGE	MAX WATTS	EFFICIENCY %	MAX BHP	MAX BkW	MAX AMPS	
24	Low	Vertical	HD60FK651	3.7	208	3698	85.8	4.25	3.17	10.6	
			HD60FK651	3.7	230	3698	85.8	4.25	3.17	9.6	
			HD60FK651	3.7	460	3698	85.8	4.25	3.17	4.8	
			HD60FK575	5	575	4900	87.5	5.75	4.29	6.1	
	Mid-Low	Vertical	HD60FK653	5	208	4900	87.5	5.75	4.29	16.7	
			HD60FK653	5	230	4900	87.5	5.75	4.29	15.2	
			HD60FK653	5	460	4900	87.5	5.75	4.29	7.6	
			HD60FK575	5	575	4900	87.5	5.75	4.29	6.1	
	Mid-High	Vertical	HD62FK652	7.5	208	7267	88.5	8.63	6.43	24.2	
			HD62FK652	7.5	230	7267	88.5	8.63	6.43	22	
			HD62FK652	7.5	460	7267	88.5	8.63	6.43	11	
			HD62FK576	7.5	575	7267	88.5	8.63	6.43	9	
	High	Vertical	HD64FK651	10	208	9582	89.5	11.5	8.58	30.8	
			HD64FK651	10	230	9582	89.5	11.5	8.58	28	
			HD64FK651	10	460	9582	89.5	11.5	8.58	14	
			HD64FK575	10	575	9582	89.5	11.5	8.58	11	
	Low	Horizontal	N/A	N/A	208	N/A	N/A	N/A	N/A	N/A	N/A
			N/A	N/A	230	N/A	N/A	N/A	N/A	N/A	N/A
			N/A	N/A	460	N/A	N/A	N/A	N/A	N/A	N/A
			N/A	N/A	575	N/A	N/A	N/A	N/A	N/A	N/A
	Mid-Low	Horizontal	HD60FK651	3.7	208	3698	85.8	4.25	3.17	10.6	
			HD60FK651	3.7	230	3698	85.8	4.25	3.17	9.6	
			HD60FK651	3.7	460	3698	85.8	4.25	3.17	4.8	
			HD60FK575	5	575	4900	87.5	5.75	4.29	6.1	
	Mid-High	Horizontal	HD60FK653	5	208	4900	87.5	5.75	4.29	16.7	
			HD60FK653	5	230	4900	87.5	5.75	4.29	15.2	
			HD60FK653	5	460	4900	87.5	5.75	4.29	7.6	
			HD60FK575	5	575	4900	87.5	5.75	4.29	6.1	
High	Horizontal	HD62FK652	7.5	208	7267	88.5	8.63	6.43	24.2		
		HD62FK652	7.5	230	7267	88.5	8.63	6.43	22		
		HD62FK652	7.5	460	7267	88.5	8.63	6.43	11		
		HD62FK576	7.5	575	7267	88.5	8.63	6.43	9		
28	Low	Vertical	HD60FK653	5	208	4900	87.5	5.75	4.29	16.7	
			HD60FK653	5	230	4900	87.5	5.75	4.29	15.2	
			HD60FK653	5	460	4900	87.5	5.75	4.29	7.6	
			HD60FK575	5	575	4900	87.5	5.75	4.29	6.1	
	Mid-Low	Vertical	HD60FK653	5	208	4900	87.5	5.75	4.29	16.7	
			HD60FK653	5	230	4900	87.5	5.75	4.29	15.2	
			HD60FK653	5	460	4900	87.5	5.75	4.29	7.6	
			HD60FK575	5	575	4900	87.5	5.75	4.29	6.1	
	Mid-High	Vertical	HD62FK652	7.5	208	7267	88.5	8.63	6.43	24.2	
			HD62FK652	7.5	230	7267	88.5	8.63	6.43	22	
			HD62FK652	7.5	460	7267	88.5	8.63	6.43	11	
			HD62FK576	7.5	575	7267	88.5	8.63	6.43	9	
	High	Vertical	HD64FK651	10	208	9582	89.5	11.5	8.58	30.8	
			HD64FK651	10	230	9582	89.5	11.5	8.58	28	
			HD64FK651	10	460	9582	89.5	11.5	8.58	14	
			HD64FK575	10	575	9582	89.5	11.5	8.58	11	
	Low	Horizontal	HD60FK653	5	208	4900	87.5	5.75	4.29	16.7	
			HD60FK653	5	230	4900	87.5	5.75	4.29	15.2	
			HD60FK653	5	460	4900	87.5	5.75	4.29	7.6	
			HD60FK575	5	575	4900	87.5	5.75	4.29	6.1	
	Mid-Low	Horizontal	HD60FK653	5	208	4900	87.5	5.75	4.29	16.7	
			HD60FK653	5	230	4900	87.5	5.75	4.29	15.2	
			HD60FK653	5	460	4900	87.5	5.75	4.29	7.6	
			HD60FK575	5	575	4900	87.5	5.75	4.29	6.1	
	Mid-High	Horizontal	HD62FK652	7.5	208	7267	88.5	8.63	6.43	24.2	
			HD62FK652	7.5	230	7267	88.5	8.63	6.43	22	
			HD62FK652	7.5	460	7267	88.5	8.63	6.43	11	
			HD62FK576	7.5	575	7267	88.5	8.63	6.43	9	
High	Horizontal	HD64FK651	10	208	9582	89.5	11.5	8.58	30.8		
		HD64FK651	10	230	9582	89.5	11.5	8.58	28		
		HD64FK651	10	460	9582	89.5	11.5	8.58	14		
		HD64FK575	10	575	9582	89.5	11.5	8.58	11		

**NOTES:**

1. Extensive motor and electrical testing ensures that the motors can be utilized with confidence up to the maximum applied bhp, watts, and amps. Using the fan motor up to the maximum ratings shown will not result in nuisance tripping or premature motor failure. Unit warranty will not be affected.

2. All indoor-fan motors 5 hp and larger meet the minimum efficiency requirements as established by the Energy Policy Act of 1992 (EPACT) effective October 24, 1997.

**Table 26 — Accessory/FIOP Static Pressure (in. wg)\* — 48PG20-28**

COMPONENT	CFM								
	4,000	4,500	5,000	5,500	6,000	6,500	7,000	7,500	8,000
Economizer	0.02	0.03	0.04	0.05	0.06	0.07	0.08	0.09	0.10

COMPONENT	CFM							
	8,500	9,000	9,500	10,000	10,500	11,000	11,500	12,000
Economizer	0.11	0.12	0.13	0.15	0.16	0.17	0.19	0.20

LEGEND

**FIOP** — Factory-Installed Option

\*The static pressure must be added to the external static pressure. The sum and the evaporator entering-air cfm should then be used in conjunction with the Fan Performance tables to determine blower rpm and watts.

**Table 27 — Fan Rpm at Motor Pulley Settings\***

UNIT 48PG	DRIVE	MOTOR PULLEY TURNS OPEN												
		0	1/2	1	1 1/2	2	2 1/2	3	3 1/2	4	4 1/2	5	5 1/2	6
20 and 24 (230 and 460 volt)	Low	685	706	727	749	770	791	812	833	854	876	897	918	939
	Mid-Low	949	970	992	1013	1035	1056	1078	1099	1120	1142	1163	1185	1206
	Mid-High	941	961	980	1000	1019	1039	1059	1078	1098	1117	1137	1156	1176
	High	1014	1038	1061	1085	1108	1132	1156	1179	1203	1226	1250	1273	1297
	Low	n/a	n/a	n/a	n/a	n/a	n/a	n/a	n/a	n/a	n/a	n/a	n/a	n/a
	Mid-Low	896	924	951	979	1006	1034	1062	1089	1117	1144	1172	1199	1227
	Mid-High	1113	1138	1163	1188	1213	1238	1264	1289	1314	1339	1364	1389	1414
	High	1096	1116	1137	1157	1177	1197	1218	1238	1258	1278	1299	1319	1339
20 and 24 (575 volt)	Low	751	768	785	802	819	836	853	869	886	903	920	937	954
	Mid-Low	949	970	992	1013	1035	1056	1078	1099	1120	1142	1163	1185	1206
	Mid-High	941	961	980	1000	1019	1039	1059	1078	1098	1117	1137	1156	1176
	High	1014	1038	1061	1085	1108	1132	1156	1179	1203	1226	1250	1273	1297
	Low	n/a	n/a	n/a	n/a	n/a	n/a	n/a	n/a	n/a	n/a	n/a	n/a	n/a
	Mid-Low	873	893	912	932	951	971	991	1010	1030	1049	1069	1088	1108
	Mid-High	1113	1138	1163	1188	1213	1238	1264	1289	1314	1339	1364	1389	1414
	High	1096	1116	1137	1157	1177	1197	1218	1238	1258	1278	1299	1319	1339
28 (all voltages)	Low	687	703	718	734	749	765	780	796	811	827	842	858	873
	Mid-Low	805	822	839	856	872	889	906	923	940	957	973	990	1007
	Mid-High	941	961	980	1000	1019	1039	1059	1078	1098	1117	1137	1156	1176
	High	1014	1038	1061	1085	1108	1132	1156	1179	1203	1226	1250	1273	1297
	Low	687	703	718	734	749	765	780	796	811	827	842	858	873
	Mid-Low	805	822	839	856	872	889	906	923	940	957	973	990	1007
	Mid-High	941	961	980	1000	1019	1039	1059	1078	1098	1117	1137	1156	1176
	High	1014	1038	1061	1085	1108	1132	1156	1179	1203	1226	1250	1273	1297

LEGEND

n/a — not available

\*Approximate fan rpm shown.

NOTE: Factory pulley speed setting is at 3 turns open.

**Optional EconoMi\$er IV** — See Fig. 23 for EconoMi\$er IV component locations. The optional EconoMi\$er IV comes from the factory fully wired and assembled. No field wiring or assembly is required for standard outdoor dry bulb changeover operation. Field wiring of accessory sensors is required for different operational modes.

**ECONOMI\$ER IV STANDARD SENSORS**

**Outdoor Air Temperature (OAT) Sensor** — The outdoor air temperature sensor is a 10 to 20 mA device used to measure the outdoor-air temperature. The outdoor-air temperature is used to determine when the EconoMi\$er IV can be used for free cooling. The sensor is factory-installed on the EconoMi\$er IV in the outdoor airstream. See Fig. 24. The operating range of temperature measurement is 40 to 100 F.

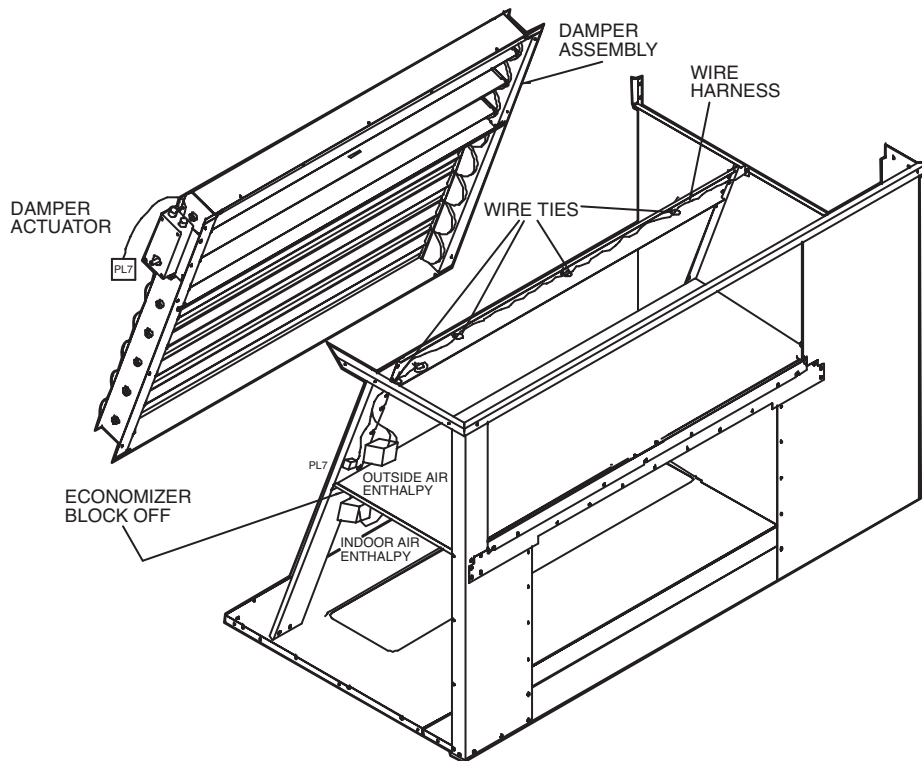
**Mixed-Air Temperature (MAT) Sensor** — The mixed-air temperature sensor is a 3 K thermistor located at the outlet of the indoor fan. See Fig. 24. This sensor is factory installed. The operating range of temperature measurement is 0° to 158 F.

The temperature sensor is a short probe with blue wires running to it.

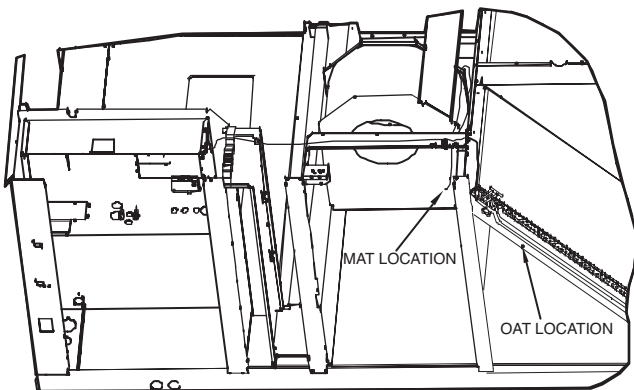
**Outdoor Air Lockout Sensor** — The EconoMi\$er IV is equipped with an ambient temperature lockout switch located in the outdoor airstream which is used to lock out the compressors below a 42 F ambient temperature.

**ECONOMI\$ER IV CONTROLLER WIRING AND OPERATIONAL MODES** — Determine the EconoMi\$er IV control mode before set up of the control. Some modes of operation may require different sensors. Refer to Table 28. The EconoMi\$er IV is supplied from the factory with a mixed-air temperature sensor and an outdoor air temperature sensor. This allows for operation of the EconoMi\$er IV with outdoor air dry bulb changeover control. Additional accessories can be added to allow for different types of changeover control and operation of the EconoMi\$er IV and unit.

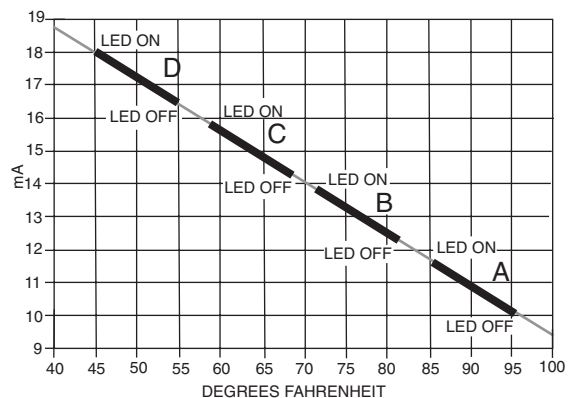
**Outdoor Dry Bulb Changeover** — The standard controller is shipped from the factory configured for outdoor dry bulb changeover control. The outdoor air and mixed-air temperature sensors are included as standard. For this control mode, the outdoor temperature is compared to an adjustable set point selected on the control. If the outdoor-air temperature is above the set point, the EconoMi\$er IV will adjust the outdoor-air dampers to minimum position. If the outdoor-air temperature is below the set point, the position of the outdoor-air dampers will be controlled to provided free cooling using outdoor air. When in this mode, the LED next to the free cooling set point potentiometer will be on. The changeover temperature set point is controlled by the free cooling set point potentiometer located on the control. The scale on the potentiometer is A, B, C, and D. See Fig. 25 for the corresponding temperature changeover values.



**Fig. 23 — EconoMiSer IV Component Locations (Exploded View)**



**Fig. 24 — Sensor Locations (OAT and MAT)**



**Fig. 25 — Temperature Changeover Set Points**

**Table 28 — EconoMiSer IV Sensor Usage**

APPLICATION	ECONOMISER IV WITH OUTDOOR AIR DRY BULB SENSOR		ECONOMISER IV WITH SINGLE ENTHALPY SENSOR			
	Accessories Required		Accessories Required			
Outdoor Air Dry Bulb	None. The outdoor air dry bulb sensor is factory installed.		CRTEMPSN002A00*			
Differential Dry Bulb	CRTEMPSN002A00*		(2) CRTEMPSN002A00*			
Single Enthalpy	HH57AC078		None. The single enthalpy sensor is factory installed.			
Differential Enthalpy	HH57AC078 and CRENTDIF004A00*		CRENTDIF004A00*			
CO <sub>2</sub> for DCV Control using a Wall-Mounted CO <sub>2</sub> Sensor	33ZCSENCO2		33ZCSENCO2			
CO <sub>2</sub> for DCV Control using a Duct-Mounted CO <sub>2</sub> Sensor	33ZCSENCO2† and 33ZCASPCO2**	† O	CRCBDIOX005A00††	33ZCSENCO2† and 33ZCASPCO2**	† O	CRCBDIOX005A00††

\*CRENTDIF004A00 and CRTEMPSN002A00 accessories are used on many different base units. As such, these kits may contain parts that will not be needed for installation.

†33ZCSENCO2 is an accessory CO<sub>2</sub> sensor.

\*\*33ZCASPCO2 is an accessory aspirator box required for duct-mounted applications.

††CRCBDIOX005A00 is an accessory that contains both 33ZCSENCO2 and 33ZCASPCO2 accessories.



**Differential Dry Bulb Control** — For differential dry bulb control the standard outdoor dry bulb sensor is used in conjunction with an additional accessory dry bulb sensor (part number CRTEMPSN002A00). The accessory sensor must be mounted in the return airstream. Wiring is provided in the EconoMi\$er IV wiring harness. See Fig. 26.

In this mode of operation, the outdoor-air temperature is compared to the return-air temperature and the lower temperature airstream is used for cooling. When using this mode of changeover control, turn the enthalpy set point potentiometer fully clockwise to the D setting.

**Outdoor Enthalpy Changeover** — For enthalpy control, accessory enthalpy sensor (part number HH57AC078) is required. Replace the standard outdoor dry bulb temperature sensor with the accessory enthalpy sensor in the same mounting location. When the outdoor air enthalpy rises above the outdoor enthalpy changeover set point, the outdoor-air damper moves to its minimum position. The outdoor enthalpy changeover set point is set with the outdoor enthalpy set point potentiometer on the EconoMi\$er IV controller. The set points are A, B, C, and D. See Fig. 27. The factory-installed 620-ohm jumper must be in place across terminals SR and + on the EconoMi\$er IV controller. See Fig. 26.

**Differential Enthalpy Control** — For differential enthalpy control, the EconoMi\$er IV controller uses two enthalpy sensors (HH57AC078 and CRENTDIF004A00), one in the outside air and one in the return air duct. The EconoMi\$er IV controller compares the outdoor air enthalpy to the return air enthalpy to determine EconoMi\$er IV use. The controller selects the lower enthalpy air (return or outdoor) for cooling. For example, when the outdoor air has a lower enthalpy than the return air, the EconoMi\$er IV opens to bring in outdoor air for free cooling.

Replace the standard outside air dry bulb temperature sensor with the accessory enthalpy sensor in the same mounting location. Mount the return air enthalpy sensor in the return air duct. Wiring is provided in the EconoMi\$er IV wiring harness. See Fig. 26. The outdoor enthalpy changeover set point is set with the outdoor enthalpy set point potentiometer on the EconoMi\$er IV controller. When using this mode of changeover control, turn the enthalpy setpoint potentiometer fully clockwise to the D setting. See Fig. 28.

**Indoor Air Quality (IAQ) Sensor Input** — The IAQ input can be used for demand control ventilation control based on the level of CO<sub>2</sub> measured in the space or return air duct.

Mount the optional IAQ sensor according to manufacturer specifications. The IAQ sensor should be wired to the AQ and AQ1 terminals of the controller. Adjust the DCV (demand controlled ventilation) potentiometers to correspond to the DCV voltage output of the indoor air quality sensor at the user-determined set point. See Fig. 29.

If a separate field-supplied transformer is used to power the IAQ sensor, the sensor must not be grounded or the EconoMi\$er IV control board will be damaged.

**Exhaust Set Point Adjustment** — The exhaust set point will determine when the exhaust fan runs based on damper position (if accessory power exhaust is installed). The set point is modified with the Exhaust Fan Set Point (EXH SET) potentiometer. See Fig. 28. The set point represents the damper position above which the exhaust fans will be turned on. When there is a call for exhaust, the EconoMi\$er IV controller provides a 45 ± 15 second delay before exhaust fan activation to allow the dampers to open. This delay allows the damper to reach the appropriate position to avoid unnecessary fan overload.

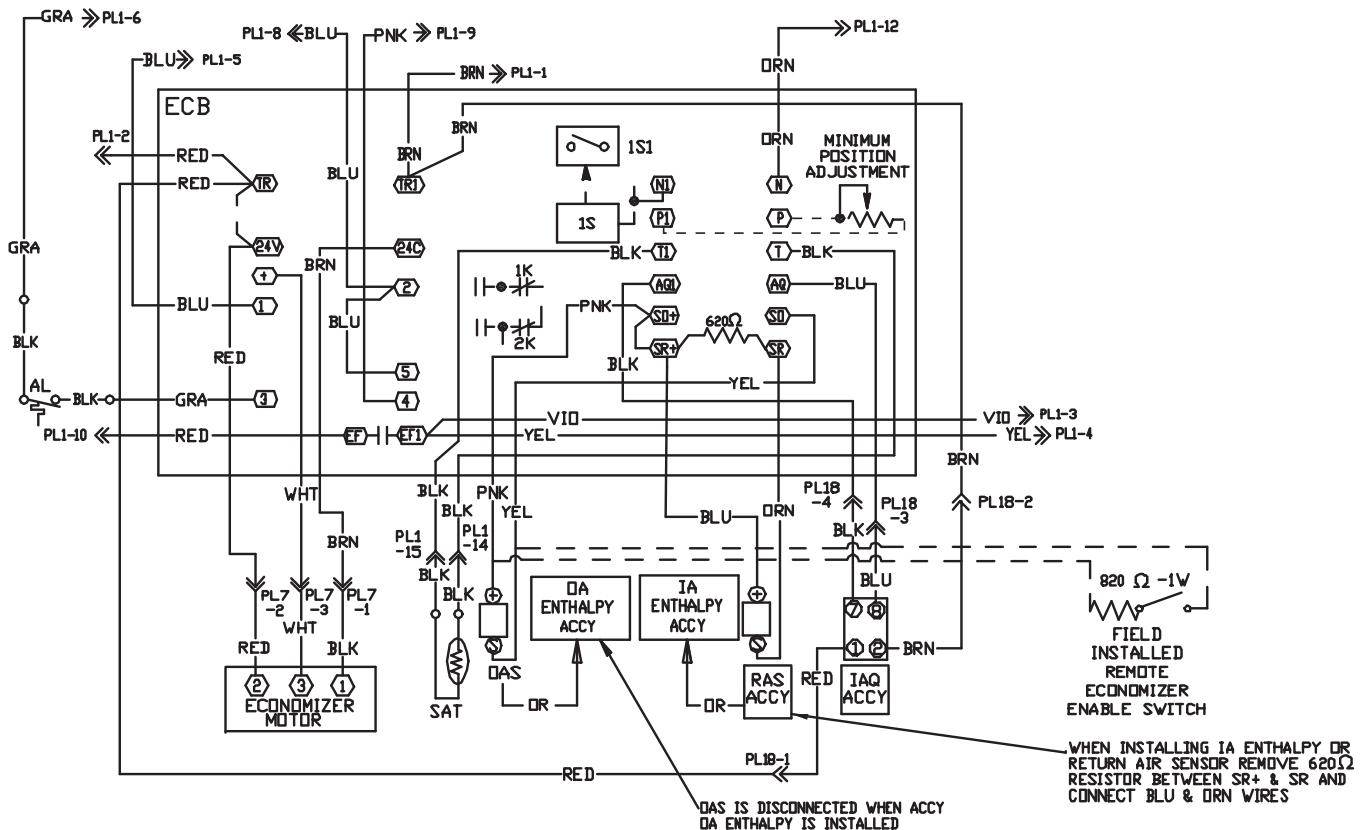
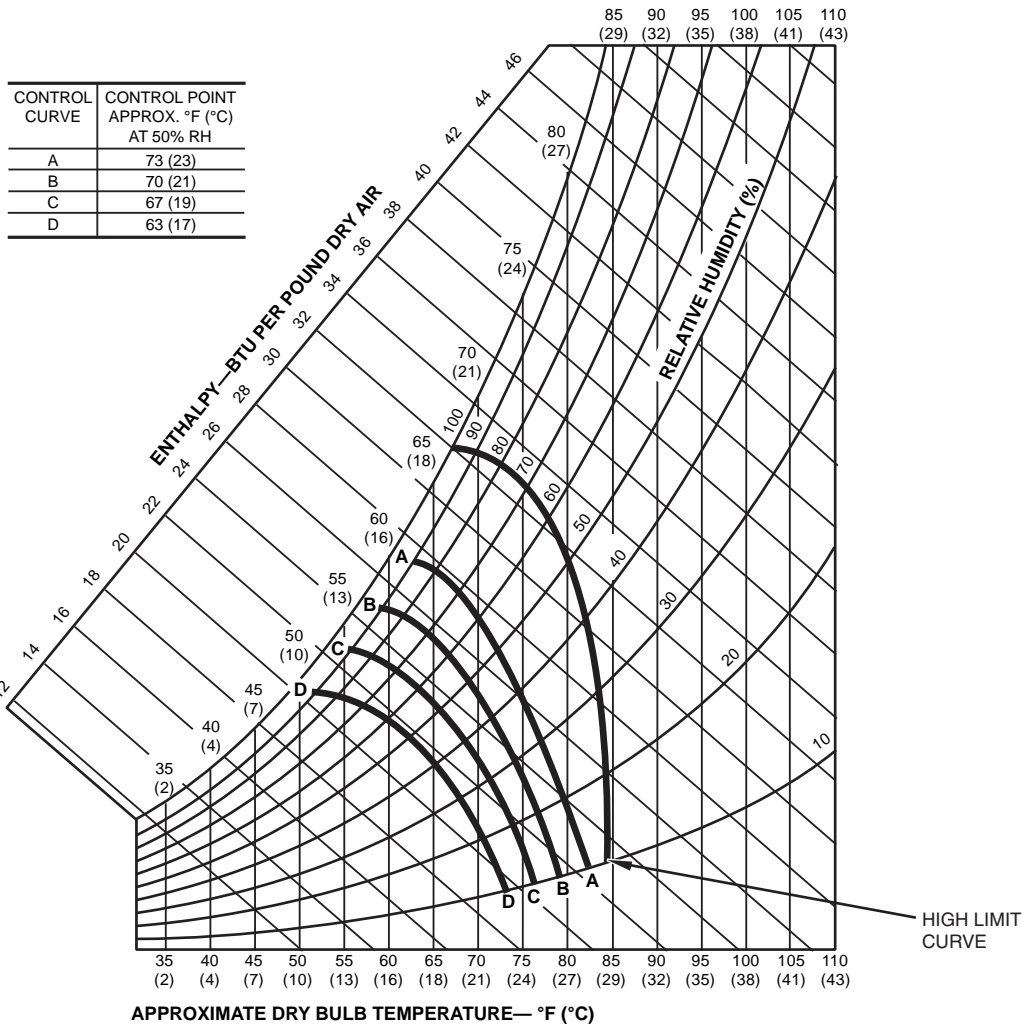
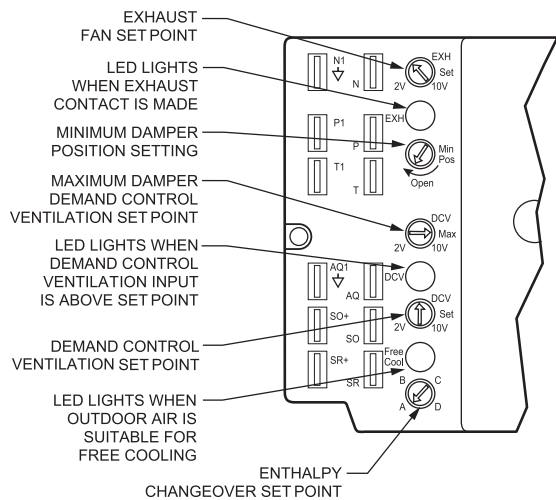


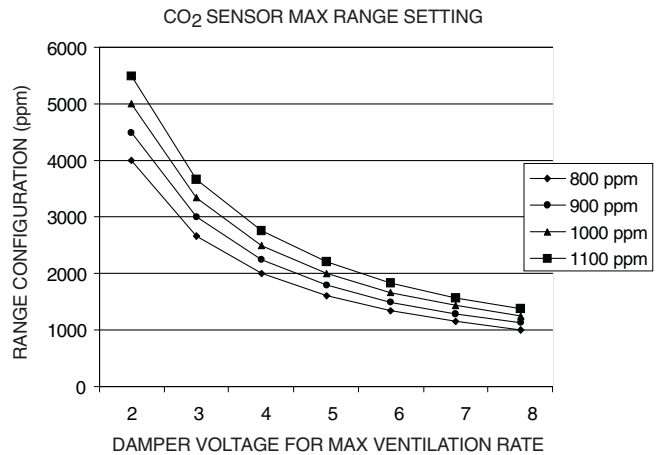
Fig. 26 — EconoMi\$er IV Wiring



**Fig. 27 — Enthalpy Changeover Set Points**



**Fig. 28 — EconoMiSer IV Controller Potentiometer and LED Locations**



**Fig. 29 — CO<sub>2</sub> Sensor Maximum Range Setting**

**Minimum Position Control** — There is a minimum damper position potentiometer on the EconoMi\$er IV controller. See Fig. 28. The minimum damper position maintains the minimum airflow into the building during the occupied period.

When using demand ventilation, the minimum damper position represents the minimum ventilation position for VOC (volatile organic compounds) ventilation requirements. The maximum demand ventilation position is used for fully occupied ventilation.

When demand ventilation control is not being used, the minimum position potentiometer should be used to set the occupied ventilation position. The maximum demand ventilation position should be turned fully clockwise.

Adjust the minimum position potentiometer to allow the minimum amount of outdoor air, as required by local codes, to enter the building. Make minimum position adjustments with at least 10° F temperature difference between the outdoor and return-air temperatures. To determine the minimum position setting, perform the following procedure:

1. Calculate the appropriate mixed air temperature using the following formula:

$$(T_O \times OA) + (T_R \times RA) = T_M$$

$T_O$  = Outdoor-Air Temperature

$OA$  = Percent of Outdoor Air

$T_R$  = Return-Air Temperature

$RA$  = Percent of Return Air

$T_M$  = Mixed-Air Temperature

As an example, if local codes require 10% outdoor air during occupied conditions, outdoor-air temperature is 60 F, and return-air temperature is 75 F.

$$(60 \times .10) + (75 \times .90) = 73.5 \text{ F}$$

2. Disconnect the mixed air sensor from terminals T and T1.
3. Ensure that the factory-installed jumper is in place across terminals P and P1. If remote damper positioning is being used, make sure that the terminals are wired according to Fig. 26 and that the minimum position potentiometer is turned fully clockwise.
4. Connect 24 vac across terminals TR and TR1.
5. Carefully adjust the minimum position potentiometer until the measured mixed air temperature matches the calculated value.
6. Reconnect the mixed air sensor to terminals T and T1.

Remote control of the EconoMi\$er IV damper is desirable when requiring additional temporary ventilation. If a field-supplied remote potentiometer (Honeywell part number S963B1128) is wired to the EconoMi\$er IV controller, the minimum position of the damper can be controlled from a remote location.

To control the minimum damper position remotely, remove the factory-installed jumper on the P and P1 terminals on the EconoMi\$er IV controller. Wire the field-supplied potentiometer to the P and P1 terminals on the EconoMi\$er IV controller. See Fig. 26.

**Damper Movement** — When the EconoMi\$er IV board receives initial power, it can take the damper up to 2½ minutes before it begins to position itself. After the initial positioning, subsequent changes to damper position will take up to 30 seconds to initiate. Damper movement from full open to full closed (or vice versa) takes 2½ minutes.

**Thermostats** — The EconoMi\$er IV control works with conventional thermostats that have a Y1 (cool stage 1), Y2 (cool stage 2), W1 (heat stage 1), W2 (heat stage 2), and G (fan). The EconoMi\$er IV control does not support space temperature sensors like the T55 or T56. Connections are made at the thermostat terminal connection board located in the main control box.

**Demand Control Ventilation** — When using the EconoMi\$er IV for demand control ventilation, there are some equipment selection criteria which should be considered. When selecting the heat capacity and cool capacity of the equipment, the maximum ventilation rate must be evaluated for design conditions. The maximum damper position must be calculated to provide the desired fresh air.

Typically the maximum ventilation rate will be about 5 to 10% more than the typical cfm required per person, using normal outside air design criteria.

A proportional anticipatory strategy should be taken with the following conditions: a zone with a large area, varied occupancy, and equipment that cannot exceed the required ventilation rate at design conditions. Exceeding the required ventilation rate means the equipment can condition air at a maximum ventilation rate that is greater than the required ventilation rate for maximum occupancy. A proportional-anticipatory strategy will cause the fresh air supplied to increase as the room CO<sub>2</sub> level increases even though the CO<sub>2</sub> set point has not been reached. By the time the CO<sub>2</sub> level reaches the set point, the damper will be at maximum ventilation and should maintain the set point.

In order to have the CO<sub>2</sub> sensor control the economizer damper in this manner, first determine the damper voltage output for minimum or base ventilation. Base ventilation is the ventilation required to remove contaminants during unoccupied periods. The following equation may be used to determine the percent of outside-air entering the building for a given damper position. For best results there should be at least a 10 degree difference in outside and return-air temperatures.

$$(T_O \times OA) + (T_R \times RA) = T_M$$

$T_O$  = Outdoor-Air Temperature

$OA$  = Percent of Outdoor Air

$T_R$  = Return-Air Temperature

$RA$  = Percent of Return Air

$T_M$  = Mixed-Air Temperature

Once base ventilation has been determined, set the minimum damper position potentiometer to the correct position.

The same equation can be used to determine the occupied or maximum ventilation rate to the building. For example, an output of 3.6 volts to the actuator provides a base ventilation rate of 5% and an output of 6.7 volts provides the maximum ventilation rate of 20% (or base plus 15 cfm per person). Use Fig. 29 to determine the maximum setting of the CO<sub>2</sub> sensor. For example, a 1100 ppm set point relates to a 15 cfm per person design. Use the 1100 ppm curve on Fig. 29 to find the point when the CO<sub>2</sub> sensor output will be 6.7 volts. Line up the point on the graph with the left side of the chart to determine that the range configuration for the CO<sub>2</sub> sensor should be 1800 ppm. The EconoMi\$er IV controller will output the 6.7 volts from the CO<sub>2</sub> sensor to the actuator when the CO<sub>2</sub> concentration in the space is at 1100 ppm. The DCV set point may be left at 2 volts since the CO<sub>2</sub> sensor voltage will be ignored by the EconoMi\$er IV controller until it rises above the 3.6 volt setting of the minimum position potentiometer.

Once the fully occupied damper position has been determined, set the maximum damper demand control ventilation potentiometer to this position. Do not set to the maximum position as this can result in over-ventilation to the space and potential high-humidity levels.

**CO<sub>2</sub> Sensor Configuration** — The CO<sub>2</sub> sensor has preset standard voltage settings that can be selected anytime after the sensor is powered up. See Table 29.

Use setting 1 or 2 for Carrier equipment. See Table 29.

1. Press Clear and Mode buttons. Hold at least 5 seconds until the sensor enters the Edit mode.
2. Press Mode twice. The STDSET Menu will appear.

3. Use the Up/Down button to select the preset number. See Table 29.
4. Press Enter to lock in the selection.
5. Press Mode to exit and resume normal operation.

The custom settings of the CO<sub>2</sub> sensor can be changed anytime after the sensor is energized. Follow the steps below to change the non-standard settings:

1. Press Clear and Mode buttons. Hold at least 5 seconds until the sensor enters the Edit mode.
2. Press Mode twice. The STDSET Menu will appear.
3. Use the Up/Down button to toggle to the NONSTD menu and press Enter.
4. Use the Up/Down button to toggle through each of the nine variables, starting with Altitude, until the desired setting is reached.
5. Press Mode to move through the variables.
6. Press Enter to lock in the selection, then press Mode to continue to the next variable.

**Dehumidification of Fresh Air with DCV Control** — Information from ASHRAE (American Society of Heating, Refrigeration, and Air Conditioning Engineers) indicates that the largest humidity load on any zone is the fresh air introduced. For some applications, a device such as a 62AQ energy recovery unit is added to reduce the moisture content of the fresh air being brought into the building when the enthalpy is high. In most cases, the normal heating and cooling processes are more than adequate to remove the humidity loads for most commercial applications.

This makes the control of the of the dehumidification device simple when using the enthalpy or differential enthalpy sensor. The enthalpy sensor or differential enthalpy sensor is installed on the equipment to determine economizer operation. The high enthalpy signal from the enthalpy sensor or differential enthalpy sensor can be used to turn on the outdoor air moisture removal device any time fresh air is required for the space.

The energy recovery device should be sized for maximum latent and sensible conditioning at maximum ventilation on a design day. A calculation for leaving-air temperature on a low ambient, low ventilation day should also be done to determine the mixed-air temperature of the return and pre-conditioned

outside air. The design should produce an air temperature somewhat near room conditions to prevent reheat of the air mixture. The energy recovery device should be interlocked with the heat to turn off the device when in the heat mode.

## Operating Sequence

**COOLING, UNITS WITHOUT ECONOMIZER** — When the thermostat calls for one stage of cooling, Y1 and G are energized. The indoor-fan contactor (IFC) and compressor contactor(s) (C.A1 and C.B1 on three-compressor units or C.A1 only on two-compressor units), and outdoor-fan contactors (OFC1 and OFC2 when outdoor temperature is above LTS setting) are energized and the indoor-fan motor, compressor(s) (A1 and B1 on three compressor units or A1 only on two-compressor units), and outdoor fans controlled by OFC1 are started. If the outdoor temperature is above the setting of the low temperature switch, the outdoor fans controlled by OFC2 are also started.

If more cooling is required, the thermostat will call for a second stage of cooling, energizing Y2. This will allow relay CR1 to energize, which in turn energizes the compressor contactor (C.C1 on three-compressor units or C.B1 on two-compressor units). The second stage compressor (C1 on three-compressor units or B1 on two-compressor units is then started.

## HEATING, UNITS WITHOUT ECONOMIZER

NOTE: The 48PG20-28 units have 2 stages of heat.

When the thermostat calls for heating, power is sent to W on the IGC (integrated gas unit controller) board. An LED (light-emitting diode) on the IGC board will be on during normal operation. A check is made to ensure that the rollout switch and limit switch are closed and the induced-draft motor is running. The induced-draft motor is then energized, and when speed is proven with the hall effect sensor on the motor, the ignition activation period begins. The burners will ignite within 5 seconds.

If the burners do not light, there is a 22-second delay before another 5-second attempt. If the burners still do not light, this sequence is repeated for 15 minutes. After the 15 minutes have elapsed, if the burners still have not lit, heating is locked out. To reset the control, break 24-v power to the thermostat.

**Table 29 — CO<sub>2</sub> Sensor Standard Settings**

SETTING	EQUIPMENT	OUTPUT	VENTILATION RATE (cfm/Person)	ANALOG OUTPUT	CO <sub>2</sub> CONTROL RANGE (ppm)	OPTIONAL RELAY SETPOINT (ppm)	RELAY HYSTERESIS (ppm)
1	Interface w/Standard Building Control System	Proportional	Any	0-10V 4-20 mA	0-2000	1000	50
2		Proportional	Any	2-10V 7-20 mA	0-2000	1000	50
3		Exponential	Any	0-10V 4-20 mA	0-2000	1100	50
4	Economizer	Proportional	15	0-10V 4-20 mA	0-1100	1100	50
5		Proportional	20	0-10V 4-20 mA	0- 900	900	50
6		Exponential	15	0-10V 4-20 mA	0-1100	1100	50
7		Exponential	20	0-10V 4-20 mA	0- 900	900	50
8	Health & Safety	Proportional	—	0-10V 4-20 mA	0-9999	5000	500
9	Parking/Air Intakes/ Loading Docks	Proportional	—	0-10V 4-20 mA	0-2000	700	50

### LEGEND

PPM — Parts Per Million

When ignition occurs the IGC board will continue to monitor the condition of the rollout and limit switches, the hall effect sensor, as well as the flame sensor. If the unit is controlled through a room thermostat set for fan auto., 45 seconds after ignition occurs, the indoor-fan motor will be energized (and the outdoor-air dampers will open to their minimum position). If for some reason the overtemperature limit opens prior to the start of the indoor fan blower, on the next attempt, the 45-second delay will be shortened to 5 seconds less than the time from initiation of heat to when the limit tripped. Gas will not be interrupted to the burners and heating will continue. Once modified, the fan on delay will not change back to 45 seconds unless power is reset to the control.

When additional heat is required, W2 closes and initiates power to the second stage of the main gas valve. When the thermostat is satisfied, W1 and W2 open and the gas valve closes, interrupting the flow of gas to the main burners. If the call for W1 lasted less than 1 minute, the heating cycle will not terminate until 1 minute after W1 became active. If the unit is controlled through a room thermostat set for fan auto., the indoor-fan motor will continue to operate for an additional 45 seconds then stop (and the outdoor-air dampers will close). If the overtemperature limit opens after the indoor motor is stopped within 10 minutes of W1 becoming inactive, on the next cycle the time will be extended by 15 seconds. The maximum delay is 3 minutes. Once modified, the fan off delay will not change back to 45 seconds unless power is reset to the control.

A LED indicator is provided on the IGC to monitor operation. The IGC is located by removing the side panel and viewing the IGC through the view port located in the control box access panel. During normal operation, the LED is continuously on. For information on troubleshooting refer to page 57.

**COOLING, UNITS WITH ECONOMISER IV** — When free cooling is not available, the compressors will be controlled by the zone thermostat. When free cooling is available, the outdoor-air damper is modulated by the EconoMi\$er IV control to provide a 50 to 55 F mixed-air temperature into the zone. As the mixed-air temperature fluctuates above 55 or below 50 F, the dampers will be modulated (open or close) to bring the mixed air temperature back within control.

If mechanical cooling is utilized with free cooling, the outdoor-air damper will maintain its current position at the time the compressor is started. If the increase in cooling capacity causes the mixed-air temperature to drop below 45 F, then the outdoor-air damper position will be decreased to the minimum position. If the mixed-air temperature continues to fall, the outdoor-air damper will close. Control returns to normal once the mixed-air temperature rises above 48 F.

If optional power exhaust is installed, as the outdoor-air damper opens and closes, the power exhaust fans will be energized and deenergized.

If field-installed accessory CO<sub>2</sub> sensors are connected to the EconoMi\$er IV control, a demand controlled ventilation strategy will begin to operate. As the CO<sub>2</sub> level in the zone increases above the CO<sub>2</sub> set point, the minimum position of the damper will be increased proportionally. As the CO<sub>2</sub> level decreases because of the increase in fresh air, the outdoor-air damper will be proportionally closed.

For EconoMi\$er IV operation, there must be a thermostat call for the fan (G). This will move the damper to its minimum position.

When the EconoMi\$er IV control is in the occupied mode and a call for cooling exists (Y1 on the thermostat), the control will first check for indoor fan operation. If the fan is not on, then cooling will not be activated. If the fan is on, then the control will open the EconoMi\$er IV damper to the minimum position.

On the initial power to the EconoMi\$er IV control, it will take the damper up to 2½ minutes before it begins to position itself. Any change in damper position will take up to 30 seconds to initiate. Damper movement from full closed to full open (or vice versa) will take between 1½ and 2½ minutes.

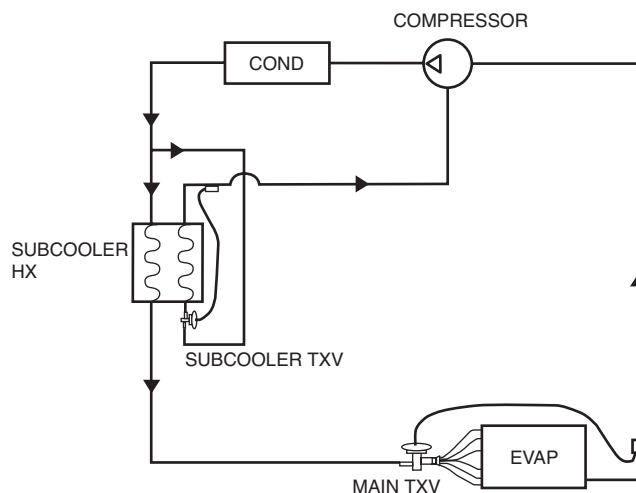
If free cooling can be used as determined from the appropriate changeover command (switch, dry bulb, enthalpy curve, differential dry bulb, or differential enthalpy), then the control will modulate the dampers open to maintain the mixed-air temperature set point at 50 to 55 F.

If there is a further demand for cooling (cooling second stage — Y2 is energized), then the control will bring on compressor stage 1 to maintain the mixed-air temperature set point. The EconoMi\$er IV damper will be open at maximum position. EconoMi\$er IV operation is limited to a single compressor.

**HEATING, UNITS WITH ECONOMISER IV** — When the room temperature calls for heat, the heating controls are energized as described in the Heating, Units Without EconoMizer section. The IFM is energized and the EconoMi\$er IV damper modulates to the minimum position. When the thermostat is satisfied and W1 and W2 are deenergized, the IFM continues to run, and the economizer damper modulates to the minimum position.

**SUBCOOLER HEAT EXCHANGER (SHX)** — The purpose of the subcooler heat exchanger (SHX) and the subcooler TXV is to increase the capacity of the evaporator by sending subcooled liquid refrigerant into the evaporator. Normally, the condenser subcools the liquid refrigerant by approximately 10 F. The SHX adds another 10 F to 15 F degrees of subcooling before the refrigerant reaches the evaporator. This allows the refrigerant to absorb more heat from the mixed air, thereby providing more cooling capacity.

The subcooler functions by taking a small percentage of the high pressure, low temperature liquid refrigerant which exits the condenser and converting it into a low pressure, low temperature gas. This is accomplished by using the subcooler TXV. The gas is then routed through a reverse-flow heat exchanger (SHX), which transfers heat from the remaining liquid refrigerant in the liquid line to the reverse flow gas refrigerant. The moderate temperature gas is then sent to the compressor to complete the loop and the cooler liquid refrigerant continues its normal path to the main TXV and the evaporator. See Fig. 30.



**Fig. 30 — Subcooler Operation**



## SERVICE

### ⚠ WARNING

Before performing service or maintenance operations on unit, turn off main power switch to unit. Electrical shock could cause personal injury.

### ⚠ CAUTION

Puron® (R-410A) refrigerant systems operate at higher pressures than standard R-22 systems. Do not use R-22 service equipment or components on Puron refrigerant equipment. If service equipment is not rated for Puron refrigerant, equipment damage or personal injury may result.

### ⚠ WARNING

1. Improper installation, adjustment, alteration, service, or maintenance can cause property damage, personal injury, or loss of life. Refer to the User's Information Manual provided with this unit for more details.
2. Do not store or use gasoline or other flammable vapors and liquids in the vicinity of this or any other appliance.

#### What to do if you smell gas:

1. DO NOT try to light any appliance.
2. DO NOT touch any electrical switch, or use any phone in your building.
3. IMMEDIATELY call your gas supplier from a neighbor's phone. Follow the gas supplier's instructions.
4. If you cannot reach your gas supplier, call the fire department.

### ⚠ WARNING

Disconnect gas piping from unit when pressure testing at pressure greater than 0.5 psig. Pressures greater than 0.5 psig will cause gas valve damage resulting in hazardous condition. If gas valve is subjected to pressure greater than 0.5 psig, it *must* be replaced before use. When pressure testing field-supplied gas piping at pressures of 0.5 psig or less, a unit connected to such piping must be isolated by closing the manual gas valve(s).

**Cleaning** — Inspect unit interior at beginning of each heating and cooling season and as operating conditions require. Remove unit top panel and/or side panels for access to unit interior. **COIL MAINTENANCE AND CLEANING RECOMMENDATION** — Routine cleaning of coil surfaces is essential to maintain proper operation of the unit. Elimination of contamination and removal of harmful residues will greatly increase the life of the coil and extend the life of the unit. The following maintenance and cleaning procedures are recommended as part of the routine maintenance activities to extend the life of the coil.

**Remove Surface Loaded Fibers** — Surface loaded fibers or dirt should be removed with a vacuum cleaner. If a vacuum cleaner is not available, a soft non-metallic bristle brush may be used. In either case, the tool should be applied in the direction of the fins. Coil surfaces can be easily damaged (fin edges can be easily bent over and damage to the coating of a protected coil) if the tool is applied across the fins.

NOTE: Use of a water stream, such as a garden hose, against a surface loaded coil will drive the fibers and dirt into the coil.

This will make cleaning efforts more difficult. Surface loaded fibers must be completely removed prior to using low velocity clean water rinse.

**Periodic Clean Water Rinse** — A periodic clean water rinse is very beneficial for coils that are applied in coastal or industrial environments. However, it is very important that the water rinse is made with very low velocity water stream to avoid damaging the fin edges. Monthly cleaning as described below is recommended.

**Routine Cleaning of Coil Surfaces** — Monthly cleaning with Totaline® environmentally sound coil cleaner is essential to extend the life of coils. This cleaner is available from Carrier Replacement parts division as part number P902-0301 for a one gallon container, and part number P902-0305 for a 5 gallon container. It is recommended that all coils, including standard aluminum, pre-coated, copper/copper or E-coated coils be cleaned with the Totaline environmentally sound coil cleaner as described below. Coil cleaning should be part of the unit's regularly scheduled maintenance procedures to ensure long life of the coil. Failure to clean the coils may result in reduced durability in the environment.

Avoid the use of:

- coil brighteners
- acid cleaning prior to painting
- high pressure washers
- poor quality water for cleaning

Totaline environmentally sound coil cleaner is non-flammable, hypoallergenic, nonbacterial, and a USDA accepted biodegradable agent that will not harm the coil or surrounding components such as electrical wiring, painted metal surfaces, or insulation. Use of non-recommended coil cleaners is strongly discouraged since coil and unit durability could be affected.

#### *Totaline Environmentally Sound Coil Cleaner Application Equipment*

- 2½ gallon garden sprayer
- water rinse with low velocity spray nozzle

### ⚠ CAUTION

Harsh chemicals, household bleach or acid or basic cleaners should not be used to clean outdoor or indoor coils of any kind. These cleaners can be very difficult to rinse out of the coil and can accelerate corrosion at the fin/tube interface where dissimilar materials are in contact. If there is dirt below the surface of the coil, use the Totaline environmentally sound coil cleaner as described above.

### ⚠ CAUTION

High velocity water from a pressure washer, garden hose, or compressed air should never be used to clean a coil. The force of the water or air jet will bend the fin edges and increase airside pressure drop. Reduced unit performance or nuisance unit shutdown may occur.

#### *Totaline Environmentally Sound Coil Cleaner Application Instructions*

1. Proper eye protection such as safety glasses is recommended during mixing and application.
2. Remove all surface loaded fibers and dirt with a vacuum cleaner as described above.
3. Thoroughly wet finned surfaces with clean water and a low velocity garden hose, being careful not to bend fins.
4. Mix Totaline environmentally sound coil cleaner in a 2½ gallon garden sprayer according to the instructions included with the cleaner. The optimum solution temperature is 100 F.

NOTE: Do NOT USE water in excess of 130 F, as the enzymatic activity will be destroyed.

5. Thoroughly apply Totaline® environmentally sound coil cleaner solution to all coil surfaces including finned area, tube sheets and coil headers.
6. Hold garden sprayer nozzle close to finned areas and apply cleaner with a vertical, up-and-down motion. Avoid spraying in horizontal pattern to minimize potential for fin damage.
7. Ensure cleaner thoroughly penetrates deep into finned areas.
8. Interior and exterior finned areas must be thoroughly cleaned.
9. Finned surfaces should remain wet with cleaning solution for 10 minutes.
10. Ensure surfaces are not allowed to dry before rinsing. Re-applying cleaner as needed to ensure 10-minute saturation is achieved.
11. Thoroughly rinse all surfaces with low velocity clean water using downward rinsing motion of water spray nozzle. Protect fins from damage from the spray nozzle.

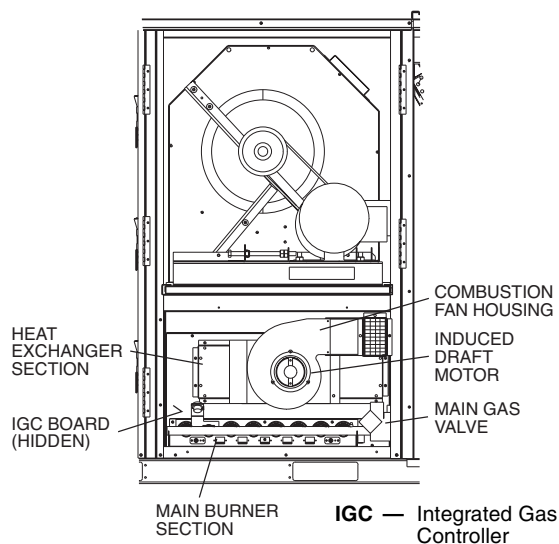
**CONDENSATE DRAIN** — Check and clean each year at the start of the cooling season. In winter, keep drains and traps dry. An access panel is located above the condensate connection to allow easy clean out of the condensate pan. The first time the panel is removed, the insulation behind the access panel will need to be cut away. Carefully cut the insulation with a knife or blade on three sides so the insulation can be folded out the way during cleaning. Be careful not to damage components behind the insulation while cutting. Once cleaning is completed, fold the insulation back into place and secure the access panel in the original position.

**FILTERS** — Clean or replace at start of each heating and cooling season, or more often if operating conditions require. Refer to Table 1 for type and size.

**OUTDOOR-AIR INLET SCREENS** — Clean screens with steam or hot water and a mild detergent. Do not use throwaway filters in place of screens. See Table 2 for quantity and size.

**MAIN BURNER** — At the beginning of each heating season, inspect for deterioration or blockage due to corrosion or other causes. Observe the main burner flames. Refer to Main Burners section on page 51.

**FLUE GAS PASSAGEWAYS** — The flue collector box and heat exchanger cells may be inspected by removing heat section access panel (Fig. 4), flue box cover, and main burner assembly (Fig. 31). Refer to Main Burners section on page 51 for burner removal sequence. If cleaning is required, clean tubes with a wire brush.



**Fig. 31 — Typical Gas Heating Section**

Use caution with ceramic heat exchanger baffles. When installing retaining clip, be sure the center leg of the clip extends inward toward baffle. See Fig. 32.

**COMBUSTION-AIR BLOWER** — Clean periodically to assure proper airflow and heating efficiency. Inspect blower wheel every fall and periodically during heating season. For the first heating season, inspect blower wheel bi-monthly to determine proper cleaning frequency.

To inspect blower wheel, remove heat section panel. Using an inspection mirror and flashlight, look into the flue exhaust duct to inspect the wheel. If cleaning is required, remove motor and wheel assembly by removing the screws holding the flue box cover to the flue box. See Fig. 31. Remove the screws holding the inducer housing to the inlet plate. The wheel can then be removed from the motor shaft and cleaned with a detergent or solvent. Replace the wheel onto the motor shaft in the correct position and reassemble the flue cover onto the flue box.

### Lubrication

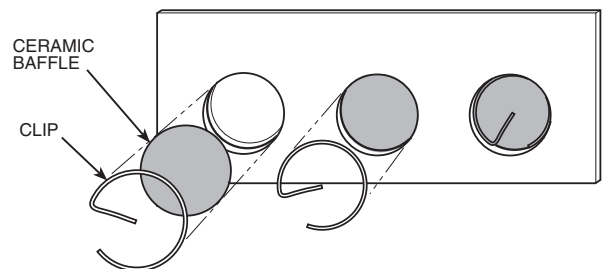
**COMPRESSORS** — Each compressor is charged with the correct amount of oil at the factory.

**⚠ CAUTION**

The compressor is in a Puron® refrigerant system and uses a polyolester (POE) oil. This oil is extremely hygroscopic, meaning it absorbs water readily. POE oils can absorb 15 times as much water as other oils designed for HCFC and CFC refrigerants. Avoid exposure of the oil to the atmosphere. Damage to components could result.

Polyolester (POE) compressor lubricants are known to cause long term damage to some synthetic roofing materials. Exposure, even if immediately cleaned up, may cause roofing materials to become brittle (leading to cracking) within a year. When performing any service which may risk exposure of compressor oil to the roof, take appropriate precautions to protect roofing. Procedures which risk oil leakage include compressor replacement, repairing refrigerant leaks, and replacing refrigerant components. To prepare rooftop:

1. Cover extended roof work area with an impermeable plastic dropcloth or tarp. Make sure a 10 x 10 area around the work area is covered.
2. Cover area in front of the unit service panel with a terry cloth shop towel to absorb lubricant spills and prevent run-offs. Towel will also protect dropcloth from tears caused by tools or components.
3. Place terrycloth shop towel inside the unit directly under components to be serviced to prevent spills through the bottom of the unit.
4. Perform the required service.
5. Remove and dispose of any oil contaminated material per local codes.



**NOTE:** One baffle and clip will be in each upper tube of the heat exchanger.

**Fig. 32 — Removing Heat Exchanger Ceramic Baffles and Clips**

FAN SHAFT BEARINGS — Lubricate bearings at least every 6 months with suitable bearing grease. Typical lubricants are given below:

MANUFACTURER	LUBRICANT
Texaco	Regal AFB-2*
Mobil	Mobilplex EP No. 1
Sunoco	Prestige 42
Texaco	Multifak 2

\*Preferred lubricant because it contains rust and oxidation inhibitors.

FAN MOTOR BEARINGS — Fan motor bearings are of the permanently lubricated type. No field lubrication is required. No lubrication of the condenser or evaporator motors are required.

**Manual Outdoor Air Damper** — If manual outdoor air damper blade adjustment is required, refer to Step 10 — Install Outdoor Air Hood section on page 12.

**Economizer Adjustment** — If economizer adjustment is required, refer to Optional EconoMiSer IV section on page 39.

**Evaporator Fan Service and Replacement** — The 48PG units feature a slide-out fan deck for easy servicing of the indoor-fan motor, pulleys, belt, and bearings. To service components in this section, perform the following procedure:

1. Turn off unit power.
2. Open the fan section access panel.
3. Remove three no. 10 screws at front of slide-out fan deck. Save screws. See Fig. 33.
4. Disconnect the limit switch wires located on the right side of the fan deck. Other wires do not need to be disconnected.
5. Fan deck can now be slid out to access serviceable components.

**CAUTION**

DO NOT SLIDE FAN DECK OUT PAST THE STOP BRACKET. If further access is required, the fan deck must be supported. Make sure plugs and wiring are not pinched between fan housing and unit center post. Damage to unit may result.

6. To replace fan deck to operating position, slide fan deck back into the unit. Secure with the three no. 10 screws removed in Step 3.
7. Re-attach electrical plugs and wires.
8. Close fan section access door.
9. Restore power to unit.

**Evaporator Fan Performance Adjustment (Fig. 33 and 34)** — Fan motor pulleys are factory set for speed shown in Table 27.

To change fan speeds:

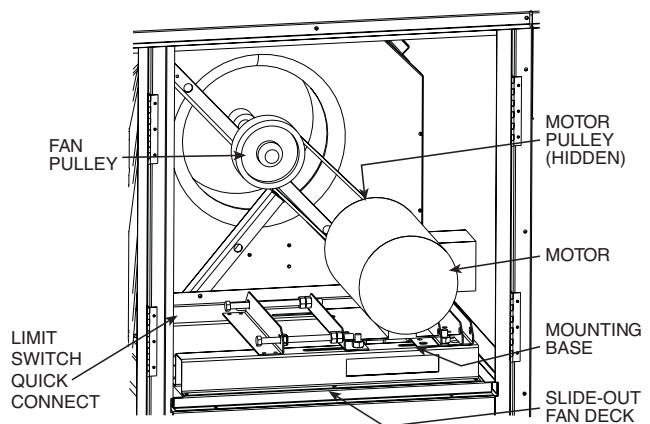
1. Shut off unit power supply.
2. Loosen nuts on the 4 carriage bolts in the mounting base. Using adjusting bolts and plate, slide motor and remove belt.
3. Loosen movable-pulley flange setscrew (see Fig. 34).
4. Screw movable flange toward fixed flange to increase speed and away from fixed flange to decrease speed. Increasing fan speed increases load on motor. Do not exceed maximum speed specified in Table 27. See Table 24 for air quantity limits.
5. Set movable flange at nearest keyway of pulley hub and tighten setscrew. (See Table 27 for speed change for each full turn of pulley flange.)
6. Replace and tighten belts (see Evaporator Fan Belt Tension Adjustment section below).
7. Restore power to unit.

To align fan and motor pulleys:

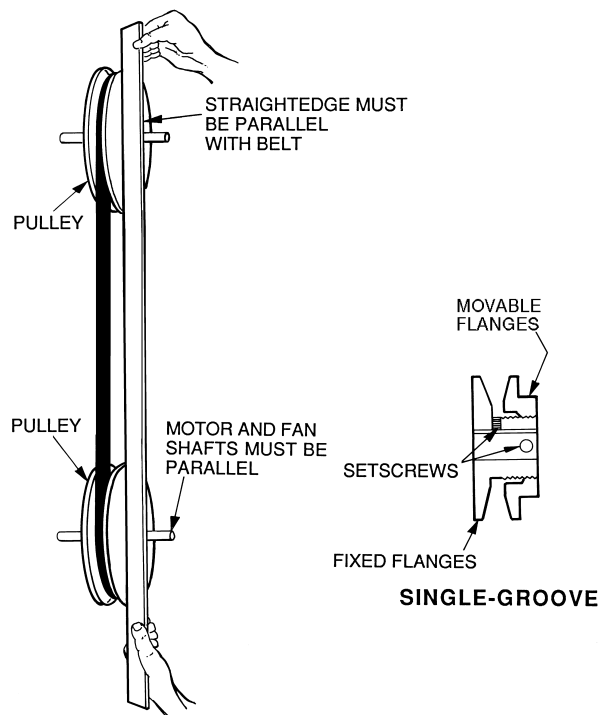
1. Loosen fan pulley setscrews.
2. Slide fan pulley along fan shaft.
3. Make angular alignment by loosening motor from mounting plate.

**Evaporator Fan Belt Tension Adjustment** — To adjust belt tension:

1. Turn off unit power.
2. Slide out fan deck to service position as shown in Evaporator Fan Service and Replacement section above.
3. Loosen fan motor bolts.
4. Move motor mounting plate to adjust to proper belt tension. See Table 30. Motor adjuster bolts may be used to tighten belts. See Fig. 33.
5. Check for proper belt alignment. Adjust if necessary.
6. Tighten motor mounting plate bolts to lock motor in proper position.
7. Return fan deck back into operating position.
8. Restore power to unit.



**Fig. 33 — Evaporator-Fan Motor Adjustment**



**Fig. 34 — Evaporator-Fan Alignment and Adjustment**

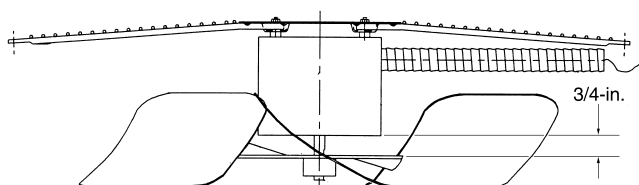


**Table 30 — Belt Tension Adjustment**

48PG	VOLTAGE	BELT TENSION (lb)							
		Unit Model Number Position 10							
		A,J	B,K	C,L	D,M	E,N	F,P	G,Q	H,R
20	230	4.8	5.1	5.6	4.5	NA	4.7	5.0	5.5
	460	4.8	5.1	5.6	4.5	NA	4.7	5.0	5.5
	575	5.3	5.1	5.6	4.5	NA	5.2	5.0	5.5
24	230	4.8	5.1	5.6	4.5	NA	4.7	5.0	5.5
	460	4.8	5.1	5.6	4.5	NA	4.7	5.0	5.5
	575	5.3	5.1	5.6	4.5	NA	5.2	5.0	5.5
28	230	4.5	5.4	5.9	4.5	4.5	5.4	5.9	4.5
	460	4.5	5.4	5.9	4.5	4.5	5.4	5.9	4.5
	575	4.5	5.4	5.9	4.5	4.5	5.4	5.9	4.5

**Condenser-Fan Adjustment (Fig. 35)**

1. Shut off unit power supply.
2. Remove condenser-fan assembly (grille, motor, motor cover, and fan) and loosen fan hub setscrews.
3. Adjust fan height as shown in Fig. 35.
4. Tighten setscrews and replace condenser-fan assembly.
5. Turn on power to unit.



**Fig. 35 — Condenser-Fan Adjustment**

**Verify Sensor Performance** — Using an ohmmeter and a thermometer, compare measured temperature to the resistance shown in Table 31.

**Table 31 — Sensor Temperature/Resistance Values**

TEMPERATURE (F)	RESISTANCE (ohms)
-58	200,250
-40	100,680
-22	53,010
-4	29,091
14	16,590
32	9,795
50	5,970
68	3,747
77	3,000
86	2,416
104	1,597
122	1,080
140	746
158	525
176	376
185	321
194	274
212	203
230	153
248	116
257	102
266	89
284	70
302	55

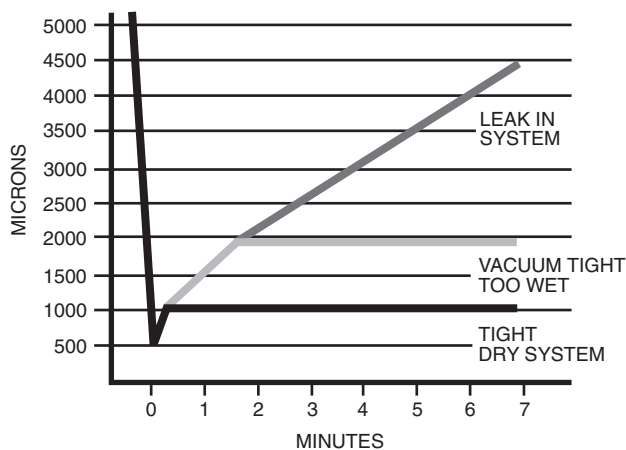
**Economizer Operation During Power Failure** — Dampers have a spring return. In event of power failure, dampers will return to fully closed position until power is restored. *Do not manually operate damper motor.*

**Evacuation** — Proper evacuation of the system will remove noncondensables and ensure a tight, dry system before charging. Evacuate from both high and low side ports. Never use the system compressor as a vacuum pump. Refrigerant tubes and indoor coil should be evacuated to 500 microns. Always break a vacuum with dry nitrogen. The two possible methods are the deep vacuum method and the triple evacuation method

**DEEP VACUUM METHOD** — The deep vacuum method requires a vacuum pump capable of pulling a minimum vacuum of 500 microns and a vacuum gage capable of accurately measuring this vacuum depth. The deep vacuum method is the most positive way of assuring a system is free of air and liquid water. (See Fig. 36.)

**TRIPLE EVACUATION METHOD** — The triple evacuation method should only be used when vacuum pump is capable of pumping down to 28 in. of mercury and system does not contain any liquid water. Proceed as follows:

1. Pump system down to 28 in. of mercury and allow pump to continue operating for an additional 15 minutes.
2. Close service valves and shut off vacuum pump.
3. Connect a nitrogen cylinder and regulator to system and open until system pressure is 2 psig.
4. Close service valve and allow system to stand for 1 hr. During this time, dry nitrogen will be able to diffuse throughout the system, absorbing moisture.
5. Repeat this procedure. System will then contain minimal amounts of contaminants and water vapor.



**Fig. 36 — Deep Vacuum Graph**

**Refrigerant Charge** — Amount of refrigerant charge is listed on unit nameplate. Refer to Carrier GTAC II; Module 5; Charging, Recovery, Recycling, and Reclamation section for charging methods and procedures. Unit panels must be in place when unit is operating during charging procedure.

Puron® (R-410A) refrigerant cylinders contain a dip tube which allows liquid refrigerant to flow from the cylinder in an upright position. Charge units with cylinder in the upright position and a commercial type metering device in the manifold hose.

**⚠ CAUTION**

This system uses Puron refrigerant which has higher pressures than R-22 and other refrigerants. No other refrigerant may be used in this system. Gage set, hoses, and recovery system must be designed to handle Puron refrigerant. If unsure about equipment, consult the equipment manufacturer.

**NOTE:** Do not use recycled refrigerant as it may contain contaminants.

**NO CHARGE** — Use standard evacuating techniques. After evacuating system, weigh in the specified amount of refrigerant (refer to unit nameplate).

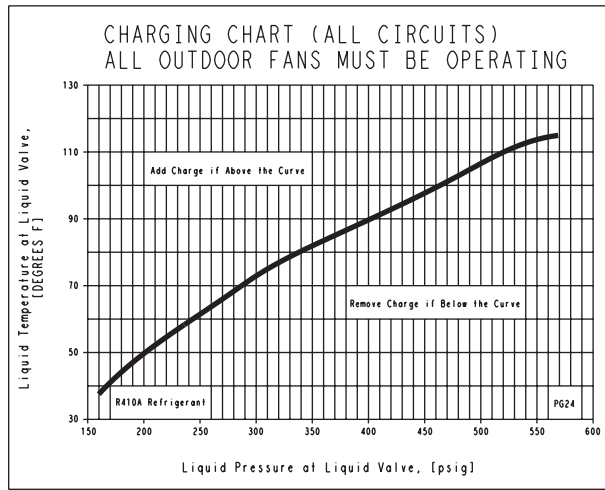
**LOW CHARGE COOLING** — Using cooling charging chart (see Fig. 37-39), add or remove refrigerant until conditions of the chart are met. An accurate pressure gage and temperature-sensing device are required. Charging is accomplished by ensuring the proper amount of liquid subcooling. Measure liquid line pressure at the liquid line service valve using pressure gage. Connect temperature sensing device to the liquid line near the liquid line service valve and insulate it so that outdoor ambient temperature does not affect reading.

**TO USE THE COOLING CHARGING CHART** — Use the above temperature and pressure readings, and find the intersection point on the cooling charging chart. If intersection point on chart is above line, add refrigerant. If intersection point on chart is below line, carefully recover some of the charge. Re-check suction pressure as charge is adjusted.

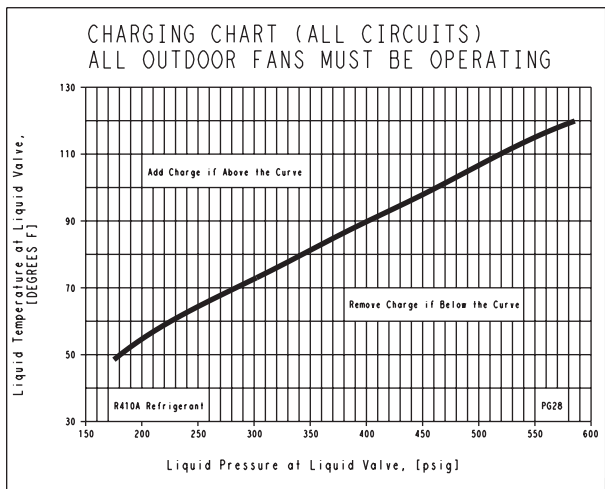
**NOTE:** Indoor-air cfm must be within normal operating range of unit. All outdoor fans must be operating.

The TXV (thermostatic expansion valve) is set to maintain between 10 and 15 degrees of superheat at the compressors. The valves are factory set and cannot be adjusted. Do not use a TXV designed for use with R-22 refrigerant.

**PURON REFRIGERANT** — Puron refrigerant operates at 50 to 70 percent higher pressures than R-22. Be sure that servicing



**Fig. 38 — Charging Chart — 48PG24**



**Fig. 39 — Charging Chart — 48PG28**

equipment and replacement components are designed to operate with Puron refrigerant. Do not mix with components that have been used with other refrigerants. Puron refrigerant, as with other HFCs, is only compatible with POE oils.

Recovery cylinder service pressure rating must be 400 psig. Puron systems should be charged with liquid refrigerant. Use a commercial-type metering device in the manifold hose. Manifold sets should be 750 psig high-side and 200 psig low-side with 520 psig low-side retard. Use hoses with 750 psig service pressure rating. Leak detectors should be designed to detect HFC refrigerant.

**Gas Valve Adjustment**

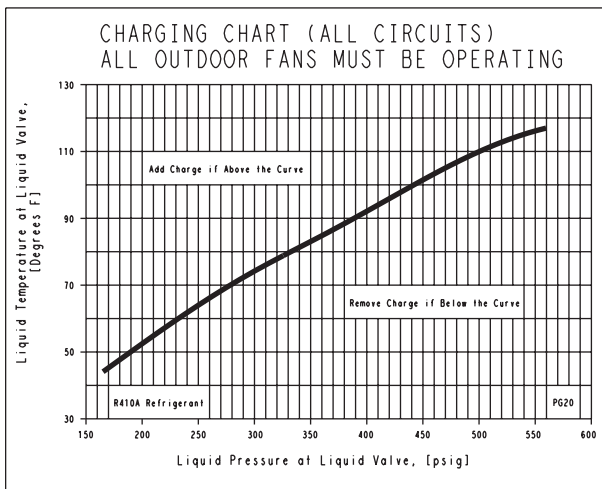
**NATURAL GAS** — The gas valve opens and closes in response to the thermostat or limit control.

When power is supplied to valve terminals W2 (High Fire) and C1, the main valve opens to its preset position.

The regular factory setting is stamped on the valve body. The setting is 3.00 in. wg for vertical supply/discharge units. The setting is 2.95 in. wg for horizontal supply/discharge units.

To adjust regulator:

1. Set unit at setting for no call for heat.
2. Turn main gas valve to OFF position.
3. Remove 1/8-in. pipe plug from manifold or gas valve pressure tap connection. Install a suitable pressure-measuring device.



**Fig. 37 — Charging Chart — 48PG20**

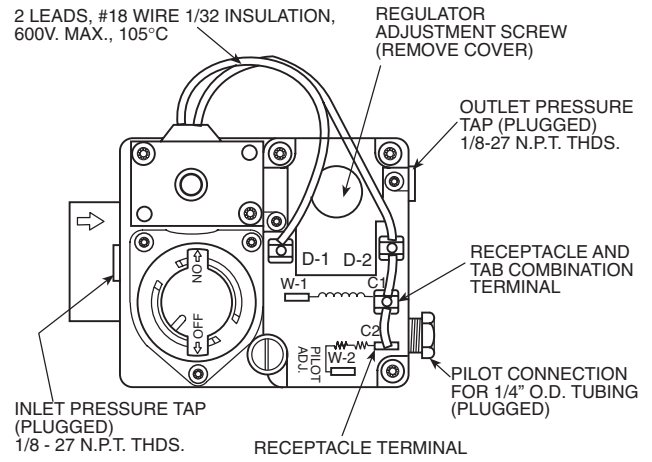
4. Set main gas valve to ON position.
5. Set thermostat at setting to call for heat.
6. Remove screw cap covering regulator adjustment screw (see Fig. 40).
7. Turn adjustment screw clockwise to increase pressure or counterclockwise to decrease pressure.
8. Once desired pressure is established, set unit setting for no call for heat, turn off main gas valve, remove pressure-measuring device, and replace 1/8-in. pipe plug and screw cap.

**High Altitude** — For high altitude applications greater than 2000 ft the heat input rate should be reduced. The higher the altitude is above sea level, the less oxygen is in the air. See Table 32 for orifice sizing. A high altitude kit is available to convert unit for altitudes up to 7,000 ft.

**Main Burners** — For all applications, main burners are factory set and should require no adjustment.

**MAIN BURNER REMOVAL**

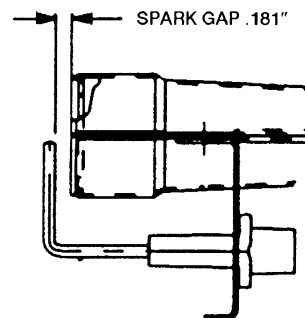
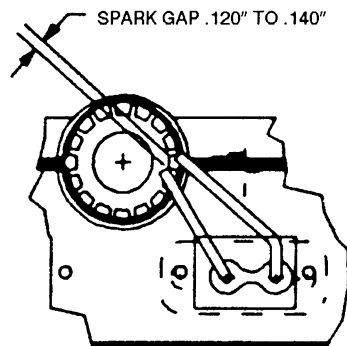
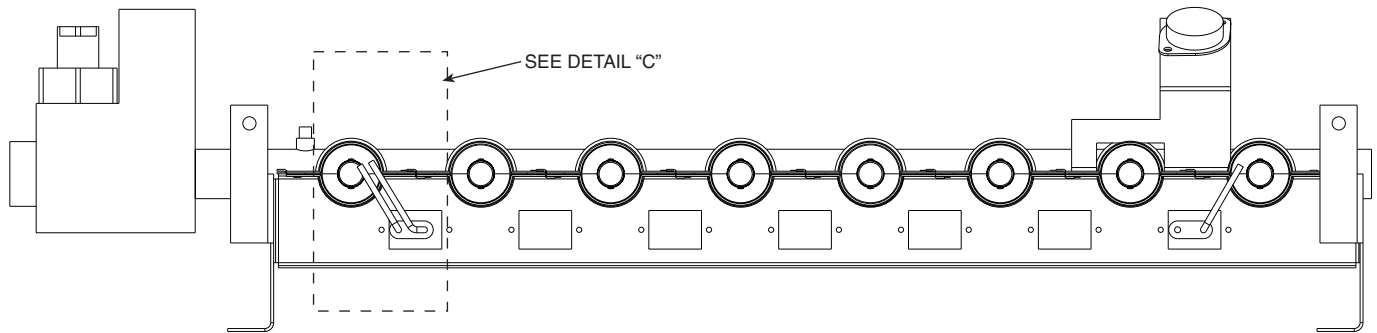
1. Shut off (field-supplied) manual main gas valve.
2. Shut off power to unit.
3. Remove gas section access panel.
4. Disconnect gas piping from gas valve inlet.
5. Remove wires from gas valve.
6. Remove wires from rollout switch.
7. Remove sensor wire and ignitor cable from IGC board.
8. Remove 2 screws securing manifold bracket to basepan.
9. Remove 2 screws that hold the burner assembly to vestibule plate.
10. Lift burner/manifold assembly out of unit.



**Fig. 40 — Gas Valve**

**CLEANING AND ADJUSTMENT**

1. Remove burner rack from unit as described in Main Burner Removal section above.
2. Inspect burners, and if dirty, remove burners from rack.
3. Using a soft brush, clean burners and crossover port as required.
4. Adjust spark gap. See Fig. 41.
5. Reinstall burners on rack.
6. Reinstall burner rack as described above.



DETAIL "C"

**Fig. 41 — Spark Gap Adjustment**

**Table 32 — Altitude Compensation\***

NATURAL GAS

ELEVATION (ft)	NATURAL GAS ORIFICE SIZE†			
	Low Heat	Medium Heat	High Heat (6 Cell)	High Heat (8 Cell)
0-1,999	29	30	29	29
2,000	29	30	29	29
3,000	30	31	30	30
4,000	30	31	30	30
5,000	30	31	30	30
6,000	30	31	30	30
7,000	31	32	31	31
8,000	31	32	31	31
9,000	31	32	31	31
10,000	32	33	32	32

\*As the height above sea level increases, there is less oxygen per cubic foot of air. Therefore, heat input rate should be reduced at higher altitudes. Includes a 4% input reduction per each 1000 ft.

†Orifices available through the local Carrier dealer.

PROPANE GAS

ELEVATION (ft)	PROPANE GAS ORIFICE SIZE†			
	Low Heat	Medium Heat	High Heat (6 Cell)	High Heat (8 Cell)
0-1,999	35	38	35	35
2,000	36	39	36	36
3,000	36	39	36	36
4,000	37	40	37	37
5,000	37	40	37	37
6,000	38	41	38	38
7,000	39	42	39	39
8,000	40	43	40	40
9,000	41	44	41	41
10,000	42	45	42	42

\*As the height above sea level increases, there is less oxygen per cubic foot of air. Therefore, heat input rate should be reduced at higher altitudes. Includes a 4% input reduction per each 1000 ft.

†Orifices available through the local Carrier dealer.

**Filter Drier** — Replace whenever refrigerant system is exposed to atmosphere. Only use factory specified liquid-line filter driers with working pressures no less than 650 psig. Do not install a suction-line filter drier in liquid line. A liquid-line filter drier designed for use with Puron® refrigerant is required for each circuit.

**Protective Devices**

COMPRESSOR PROTECTION

Overcurrent — Each compressor has internal line break motor protection.

Overtemperature — Each compressor has an internal protector to protect it against excessively high discharge gas temperatures.

High-Pressure Switch — If the high-pressure switch opens, the compressor will shut down and the compressor lockout (CLO) device will energize to block further compressor operation. The high-pressure switch will reset automatically as the refrigerant pressure drops below its reset level. The CLO will remain energized until manually reset or cooling demand is removed.

Low-Pressure Switch — If the low-pressure switch opens, the compressor will shut down and the compressor lockout (CLO) device will energize to block further compressor operation. The low-pressure switch will reset automatically as the refrigerant pressure rises above its reset level. The CLO will remain energized until manually reset or cooling demand is removed.

Freeze Protection Switch — This switch is installed on each evaporator coil section to provide protection against continued unit operation with a frosted evaporator surface. If the freeze protection switch opens, the compressor on this circuit will shut down and the compressor lockout (CLO) device will energize to block further compressor operation. The freeze protection switch will reset as the evaporator tube temperature rises above its reset level. The CLO will remain energized until manually reset or cooling demand is removed.

Compressor Lockout (CLO) Device — The CLO prevents automatic recycling of the compressor as safety controls reset. If the high-pressure switch, low-pressure switch or freeze protection switch opens, the CLO device will energize to block further compressor operation. To reset the CLO (after all safety switches have reset), either open the thermostat to remove the cooling demand signal (and then re-close) or cycle the control power in the unit.

EVAPORATOR FAN MOTOR PROTECTION — A manual reset, calibrated trip, magnetic circuit breaker protects against overcurrent. Do not bypass connections or increase the size of the breaker to correct trouble. Determine the cause and correct it before resetting the breaker.

CONDENSER-FAN MOTOR PROTECTION — Each condenser-fan motor is internally protected against overtemperature.

Fuses are also located in the control box and feed power to the condenser fan motors. Always replace blown fuses with the correct size fuse as indicated on the unit fuse label.

**Relief Devices** — All units have relief devices to protect against damage from excessive pressures (i.e., fire). These devices protect the high and low side and are located at the suction line service port. Protect joint during brazing operations near joint.

**Control Circuit, 24-V** — Each control circuit is protected against overcurrent by a 3.2 amp circuit breaker. Breaker can be reset. If it trips, determine cause of trouble before resetting. See Fig. 42-45 for schematics.

**Replacement Parts** — A complete list of replacement parts may be obtained from any Carrier distributor upon request.

**Diagnostic LEDs** — The IGC control board has a LED for diagnostic purposes. See Unit Troubleshooting section on page 57 for more information.

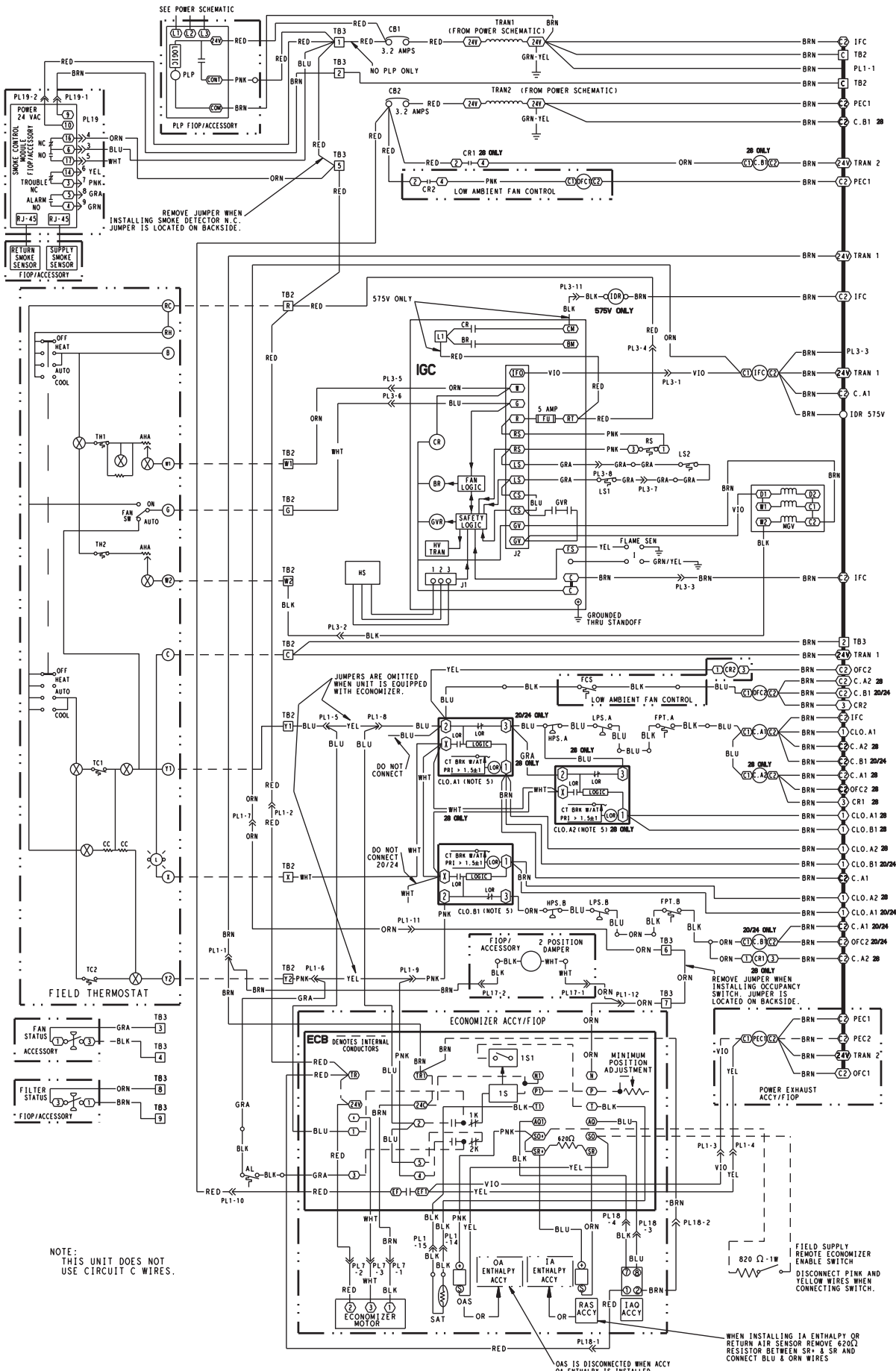


Fig. 42 — Typical Low Voltage Control Schematic

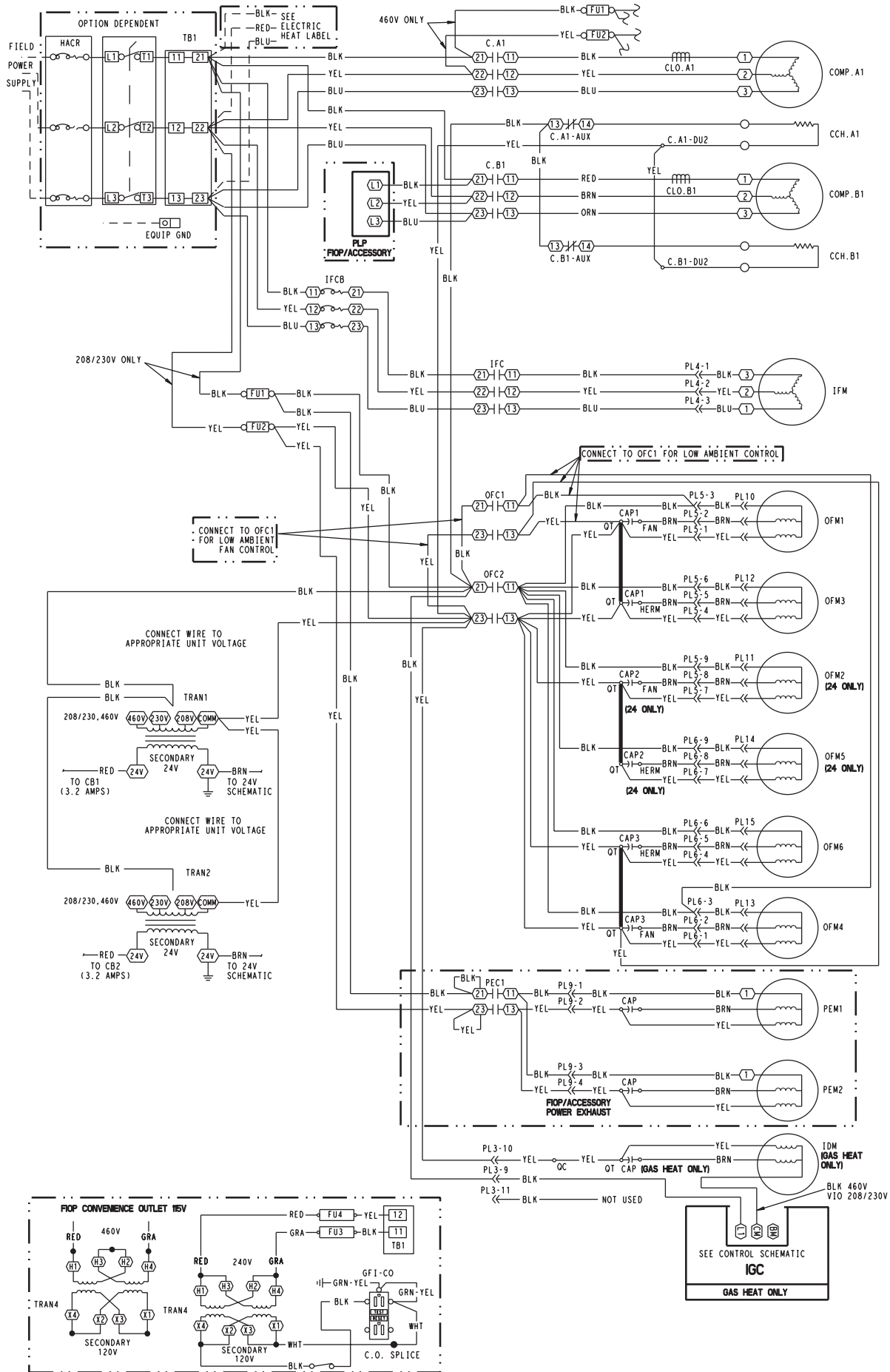


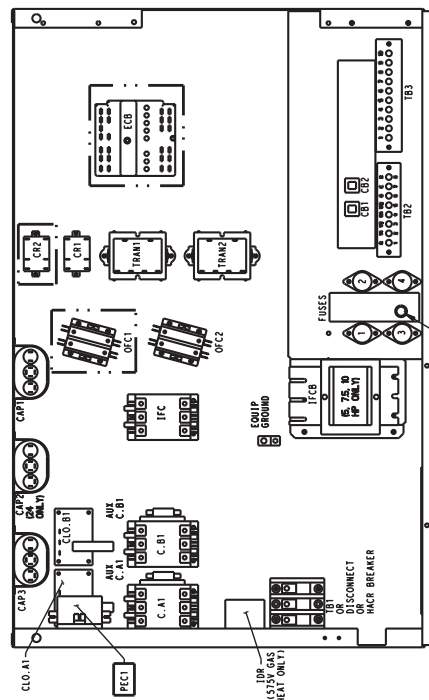
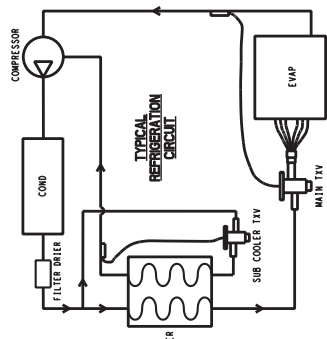
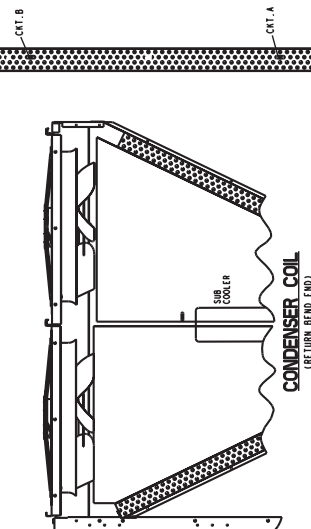
Fig. 43 — Typical Power Schematic



# COMPONENT ARRANGEMENT

PLUG LOCATION REFERENCE	PLUG LOCATION REFERENCE
PL1 (CONTROL BOX)	PL16 (FAN SECTION FAN STATUS ACCESSORY)
PL3 (HEAT SECTION PARTITION)	PL17 (ECONOMIZER MOTOR)
PL4 (FAN SECTION (INDOOR FAN MOTOR))	PL18 (COMPRESSOR SECTION)
PL5 (CONDENSER SECTION (OFM1, OFM2, OFM4, 5, 6))	PL19 (SMOKE DETECTOR CONTROL MODULE)
PL6 (ECONOMIZER SECTION)	
PL7 (ECONOMIZER MOTOR)	
PL9 (POWER EXHAUST SECTION (CONDENSER SECTION))	
PL10 (CONDENSER SECTION (OFM1))	
PL11 (CONDENSER SECTION (OFM2))	
PL12 (CONDENSER SECTION (OFM3))	
PL13 (CONDENSER SECTION (OFM4))	
PL14 (CONDENSER SECTION (OFM5))	
PL15 (CONDENSER SECTION (OFM6))	
PL16 (FAN SECTION FAN STATUS ACCESSORY)	
PL17 (ECONOMIZER MOTOR)	
PL18 (COMPRESSOR SECTION)	
PL19 (SMOKE DETECTOR CONTROL MODULE)	

FREESTAT LOCATIONS  
ELIMINATOR RETURN BEND END  
20/24



## CONTROL BOX

COMPRESSOR CONTACTORS

OUTDOOR TEMPERATURE AND P.T.  
ENTHALPY CONTROL  
ECONOMIZER MOTOR  
POWER CONVENIENCE OUTLET-OFF SWITCH

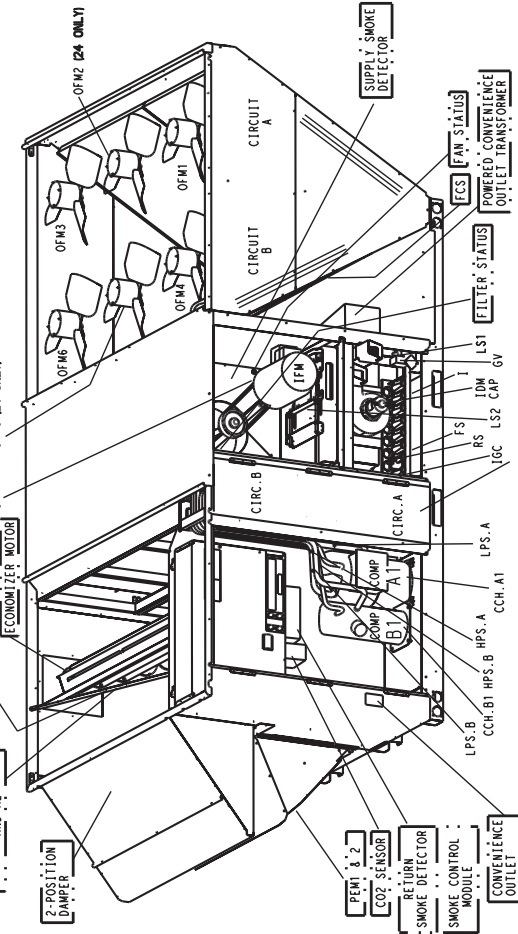
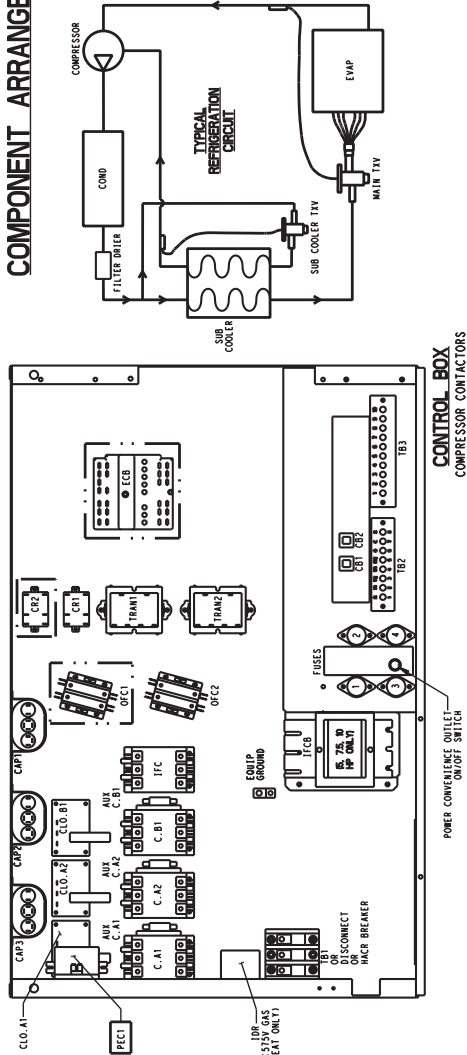
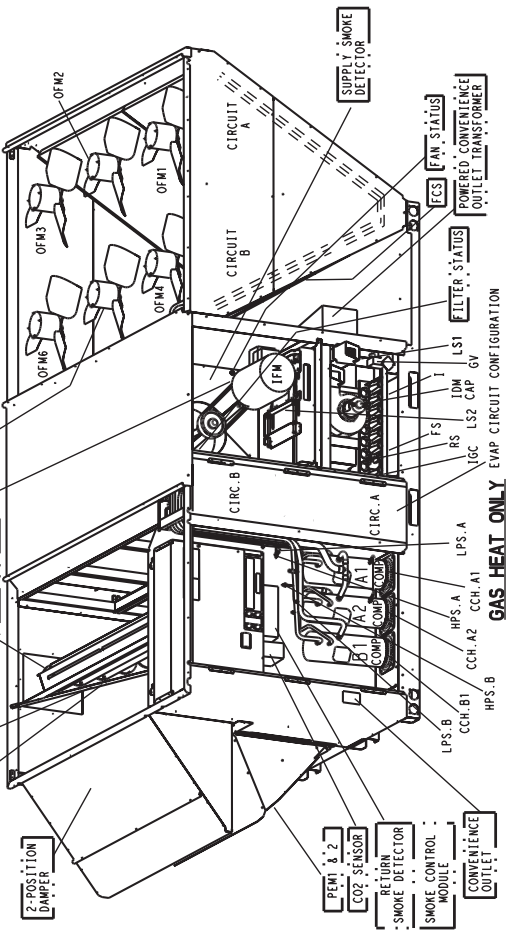
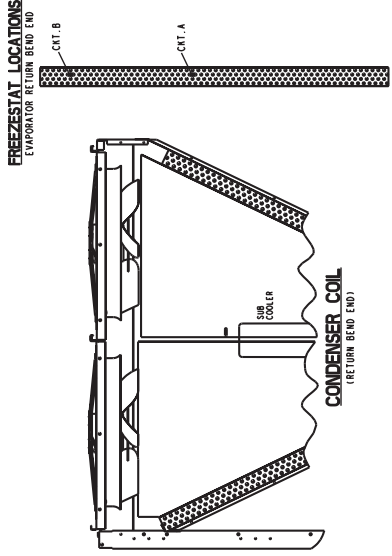


Fig. 44 — Typical Component Arrangement — 48PG20,24

### COMPONENT ARRANGEMENT



PLUG LOCATION REFERENCE	DESCRIPTION
PL1	CONTROL BOX (HEAT SECTION PARTITION)
PL3	HEAT SECTION PARTITION
PL4	FAN SECTION
PL5	CONDENSER SECTION
PL6	LOW VOLTAGE SECTION
PL7	ECONOMIZER SECTION
PL9	POWER EXHAUST MOTOR (POWER EXHAUST MOTORS)
PL10	CONDENSER SECTION
PL11	CONDENSER SECTION
PL12	CONDENSER SECTION
PL13	CONDENSER SECTION
PL14	CONDENSER SECTION
PL15	CONDENSER SECTION
PL16	FAN SECTION (FAN STATUS ACCESSORY)
PL17	CONDENSER SECTION (2-POSITION DAMPER)
PL18	COMPRESSOR SECTION
PL19	COMPRESSOR SECTION (SMOKE DETECTOR CONTROL MODULE)



### THERMOSTAT/IGC MARKINGS

- BM — Blower Motor
- C — Common
- CM — Inducer Motor
- CS — Centrifugal Switch
- G — Fan
- IFO — Indoor Fan On
- LT — Line 1
- RT — Thermostat Power
- R — Power Supply
- SS — Speed Sensor
- W — Thermostat Heat
- W1 — 1st Stage of Heating
- W2 — 2nd Stage of Heating
- X — Alarm Output
- Y1 — 1st Stage of Cooling
- Y2 — 2nd Stage of Cooling

### LEGEND FOR FIG. 42-45

- A--- Circuit A
- AUX Auxiliary Contact
- AL Ambient Limit
- B--- Circuit B
- C Compressor Contactor
- CAP Capacitor
- CB Compressor Circuit Breaker
- CCH Crankcase Heater
- CLO Compressor Lockout
- COMP Compressor
- CT BRK Control Relay
- CR Dummy Terminal
- DU Economizer Control Board
- ECB Fan Cycling Switch
- FCS Factory-installed Option
- FIO Freeze Protection Thermostat
- FPT Flame Sensor
- FS Fuse
- FU Ground
- GND Gas Valve
- GV Heating, Air Conditioning, and Refrigeration
- HACR Hermetic
- HERM High-Pressure Switch
- HPS Ignitor
- I Indoor Air Quality
- IAQ Induced-Draft Motor
- IDM Induced Draft Relay
- IDR Indoor-Fan Contactor
- IFC Indoor-Fan Circuit Breaker
- IFM Indoor-Fan Motor
- IGC Integrated Gas Controller
- LOR Lockout Relay
- LPS Low-Pressure Switch
- LS Limit Switch
- OAS Outdoor-Air Sensor
- OFC Outdoor-Fan Contactor
- OFM Outdoor-Fan Motor
- PEC Power Exhaust Contactor
- PEM Power Exhaust Motor
- PL Plug
- PLP Phase Loss Protection
- QC Quick Connect
- QT Quadruple Terminal
- RAS Return Air Sensor
- RS Rollout Switch
- SAT Supply-Air Temperature
- TB Terminal Block
- TRAN Transformer
- TXV Thermostatic Expansion Valve
- W/AT With Auxiliary Trip
- X Terminal Block
- Terminal (Unmarked)
- ◇ Terminal (Marked)
- Factory Wiring
- - - Field Wiring
- To Indicate Common Potential Only, Not to Represent Wiring.
- · - · - To Indicate FIO or Accessory

Fig. 45 — Typical Component Arrangement — 48PG28

- NOTES:
1. Factory wiring is in accordance with the National Electrical Codes. Any field modifications or additions must be in compliance with all applicable codes.
  2. Use 75° C min wire for field power supply. Use copper wires for all units.
  3. All circuit breakers "Must Trip Amps" are equal to or less than 156% RLA.
  4. Compressor and fan motors are thermally protected. Three-phase motors protected against primary single-phase conditions.
  5. The CLO locks out the compressor to prevent short cycling on compressor overload and safety devices. Before replacing CLO, check these devices.



## TROUBLESHOOTING

**Unit Troubleshooting** — Refer to Tables 33-35 and Fig. 46.

**Table 33 — Cooling Service Analysis**

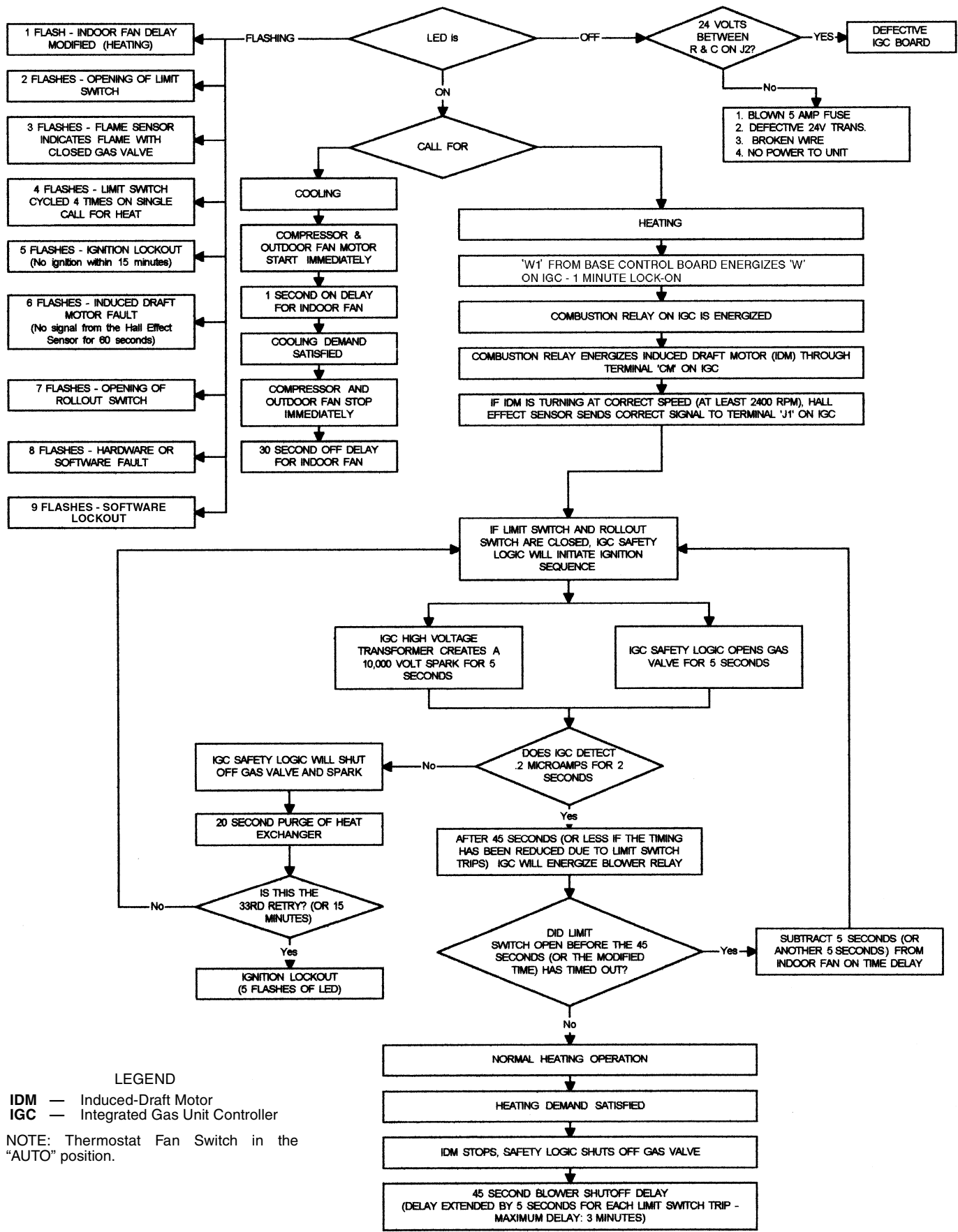
PROBLEM	CAUSE	REMEDY
<b>Compressor and Condenser Fan Will Not Start.</b>	Power failure.	Call power company.
	Fuse blown or circuit breaker tripped.	Replace fuse or reset circuit breaker.
	Defective thermostat, contactor, transformer, or control relay.	Replace component.
	Insufficient line voltage.	Determine cause and correct.
	Incorrect or faulty wiring.	Check wiring diagram and rewire correctly.
	Thermostat setting too high.	Lower thermostat setting below room temperature.
<b>Compressor Will Not Start but Condenser Fan Runs.</b>	Faulty wiring or loose connections in compressor circuit.	Check wiring and repair or replace.
	Compressor motor burned out, seized, or internal overload open.	Determine cause. Replace compressor.
	Defective overload.	Determine cause and replace.
	Compressor locked out	Determine cause for safety trip and reset lockout.
	One leg of 3-phase power dead.	Replace fuse or reset circuit breaker. Determine cause.
<b>Compressor Cycles (other than normally satisfying thermostat).</b>	Refrigerant overcharge or undercharge.	Recover refrigerant, evacuate system, and recharge to nameplate.
	Defective compressor.	Replace and determine cause.
	Insufficient line voltage.	Determine cause and correct.
	Blocked condenser.	Determine cause and correct.
	Defective overload.	Determine cause and replace.
	Defective thermostat.	Replace thermostat.
	Faulty condenser-fan motor.	Replace.
	Restriction in refrigerant system.	Locate restriction and remove.
<b>Compressor Operates continuously.</b>	Dirty air filter.	Replace filter.
	Unit undersized for load.	Decrease load or increase unit size.
	Thermostat set too low.	Reset thermostat.
	Low refrigerant charge.	Locate leak, repair, and recharge.
	Air in system.	Recover refrigerant, evacuate system, and recharge.
	Condenser coil dirty or restricted.	Clean coil or remove restriction.
	<b>Excessive Head Pressure.</b>	Dirty air filter.
Dirty condenser coil.		Clean coil.
Refrigerant overcharged.		Recover excess refrigerant.
Faulty TXV.		1. Check TXV bulb mounting and secure tightly to suction line. 2. Replace TXV if stuck open or closed.
Air in system.		Recover refrigerant, evacuate system, and recharge.
Condenser air restricted or air short-cycling.		Determine cause and correct.
<b>Head Pressure Too Low.</b>	Low refrigerant charge.	Check for leaks, repair, and recharge.
	Restriction in liquid tube.	Remove restriction.
<b>Excessive Suction Pressure.</b>	High heat load.	Check for source and eliminate.
	Faulty TXV.	1. Check TXV bulb mounting and secure tightly to suction line. 2. Replace TXV if stuck open or closed.
	Refrigerant overcharged.	Recover excess refrigerant.
<b>Suction Pressure Too Low.</b>	Dirty air filter.	Replace filter.
	Low refrigerant charge.	Check for leaks, repair, and recharge.
	Metering device or low side restricted.	Remove source of restriction.
	Faulty TXV.	1. Check TXV bulb mounting and secure tightly to suction line. 2. Replace TXV if stuck open or closed.
	Insufficient evaporator airflow.	Increase air quantity. Check filter and replace if necessary.
	Temperature too low in conditioned area.	Reset thermostat.
	Field-installed filter drier restricted.	Replace.

LEGEND

**TXV** — Thermostatic Expansion Valve

**Table 34 — Gas Heating Service Analysis**

<b>PROBLEM</b>	<b>CAUSE</b>	<b>REMEDY</b>
<b>Burners Will Not Ignite.</b>	Misaligned spark electrodes.	Check flame ignition and sensor electrode positioning. Adjust as needed.
	No gas at main burners.	Check gas line for air; purge as necessary. After purging gas line of air, allow gas to dissipate for at least 5 minutes before attempting to relight unit. Check gas valve.
	Water in gas line.	Drain water and install drip leg to trap water.
	No power to furnace.	Check power supply, fuses, wiring, and circuit breaker.
	No 24 v power supply to control circuit.	Check transformer. Transformers with internal overcurrent protection require a cool-down period before resetting. Check 24-v circuit breaker; reset if necessary.
	Miswired or loose connections.	Check all wiring and wire nut connections.
	Burned-out heat anticipator in thermostat.	Replace thermostat.
<b>Inadequate Heating.</b>	Broken thermostat wires.	Run continuity check. Replace wires if necessary.
	Dirty air filter.	Clean or replace filter as necessary.
	Gas input to unit too low.	Check gas pressure at manifold. Clock gas meter for input. If too low, increase manifold pressure or replace with correct orifices.
	Unit undersized for application.	Replace with proper unit or add additional unit.
	Restricted airflow.	Clean filter, replace filter, or remove any restrictions.
	Blower speed too low.	Install alternate motor, if applicable, or adjust pulley to increase fan speed.
	Limit switch cycles main burners.	Check rotation of blower, thermostat heat anticipator settings, and temperature rise of unit. Adjust as needed.
<b>Poor Flame Characteristics.</b>	Incomplete combustion (lack of combustion air) results in: Aldehyde odors, CO, sooting flame, or floating flame.	Too much outdoor air. Adjust minimum position. Check economizer operation.
		Incomplete combustion (lack of combustion air) results in: Aldehyde odors, CO, sooting flame, or floating flame. Check all screws around flue outlets and burner compartment. Tighten as necessary.
		Cracked heat exchanger. Replace heat exchanger.
		Overfired unit — reduce input, change orifices, or adjust gas line or manifold pressure. Check vent for restriction. Clean as necessary.
<b>Burners Will Not Turn Off.</b>	Check orifice to burner alignment.	
	Unit is locked into Heating mode for a one minute minimum.	Wait until mandatory one minute time period has elapsed or power to unit.



**LEGEND**  
 IDM — Induced-Draft Motor  
 IGC — Integrated Gas Unit Controller

NOTE: Thermostat Fan Switch in the "AUTO" position.

Fig. 46 — IGC Control (Heating and Cooling)

**Table 35 — IGC Board LED Alarm Codes**

LED FLASH CODE	DESCRIPTION	ACTION TAKEN BY CONTROL	RESET METHOD	PROBABLE CAUSE
On	Normal Operation	—	—	—
Off	Hardware Failure	No gas heating.	—	Loss of power to the IGC. Check 5 amp fuse on IGC, power to unit, 24V circuit breaker, transformer, and wiring to the IGC.
1 Flash	Indoor Fan On/Off Delay Modified	5 seconds subtracted from On delay. 5 seconds added to Off delay (3 min max).	Power reset.	High temperature limit switch opens during heat exchanger warm-up period before fan-on delay expires. High temperature limit switch opens within 10 minutes of heat call (W) Off. See Limit Switch Fault.
2 Flashes	Limit Switch Fault	Gas valve and igniter Off. Indoor fan and inducer On.	Limit switch closed, or heat call (W) Off.	High temperature limit switch is open. Check the operation of the indoor (evaporator) fan motor. Ensure that the supply-air temperature rise is within the range on the unit nameplate. Check wiring and limit switch operation.
3 Flashes	Flame Sense Fault	Indoor fan and inducer On.	Flame sense normal. Power reset for LED reset.	The IGC sensed a flame when the gas valve should be closed. Check wiring, flame sensor, and gas valve operation.
4 Flashes	Four Consecutive Limit Switch Fault	No gas heating.	Heat call (W) Off. Power reset for LED reset.	4 consecutive limit switch faults within a single call for heat. See Limit Switch Fault.
5 Flashes	Ignition Fault	No gas heating.	Heat call (W) Off. Power reset for LED reset.	Unit unsuccessfully attempted ignition for 15 minutes. Check igniter and flame sensor electrode spacing, gaps, etc. Check flame sense and igniter wiring. Check gas valve operation and gas supply.
6 Flashes	Induced Draft Motor Fault	If heat off: no gas heating. If heat on: gas valve Off and inducer On.	Inducer sense normal, or heat call (W) Off.	Inducer sense On when heat call Off, or inducer sense Off when heat call On. Check wiring, voltage, and operation of IGC motor. Check speed sensor wiring to IGC.
7 Flashes	Rollout Switch Lockout	Gas valve and igniter Off. Indoor fan and inducer On.	Power reset.	Rollout switch has opened. Check gas valve operation. Check induced-draft blower wheel is properly secured to motor shaft.
8 Flashes	Internal Control Lockout	No gas heating.	Power reset.	IGC has sensed internal hardware or software error. If fault is not cleared by resetting 24 v power, replace the IGC.
9 Flashes	Temporary Software Lockout	No gas heating.	1 hour auto reset, or power reset.	Electrical interference is disrupting the IGC software.

**LEGEND**

**IGC** — Integrated Gas Unit Control  
**LED** — Light-Emitting Diode

**NOTES:**

1. There is a 3-second pause between alarm code displays.
2. If more than one alarm code exists, all applicable alarm codes will be displayed in numerical sequence.
3. Alarm codes on the IGC will be lost if power to the unit is interrupted.

**EconoMi\$er IV Troubleshooting**

**ECONOMISER IV PREPARATION** — This procedure is used to prepare the EconoMi\$er IV for troubleshooting. No troubleshooting or testing is done by performing the following procedure.

**NOTE:** This procedure requires a 9-v battery, 1.2 kilo-ohm resistor, and a 5.6 kilo-ohm resistor which are not supplied with the EconoMi\$er IV.

**IMPORTANT:** Be sure to record the positions of all potentiometers before starting troubleshooting.

1. Disconnect power at TR and TR1. All LEDs should be off. Exhaust fan contacts should be open.
2. Disconnect device at P and P1.
3. Jumper P to P1.
4. Disconnect wires at T and T1. Place 5.6 kilo-ohm resistor across T and T1.
5. Jumper TR to 1.
6. Jumper TR to N.
7. If connected, remove sensor from terminals S<sub>O</sub> and +. Connect 1.2 kilo-ohm 4074EJM checkout resistor across terminals S<sub>O</sub> and +.
8. Put 620-ohm resistor across terminals S<sub>R</sub> and +.
9. Set minimum position, DCV set point, and exhaust potentiometers fully CCW (counterclockwise).

10. Set DCV maximum position potentiometer fully CW (clockwise).
11. Set enthalpy potentiometer to D.
12. Apply power (24 vac) to terminals TR and TR1.

**DIFFERENTIAL ENTHALPY** — To check differential enthalpy:

1. Make sure EconoMi\$er IV preparation procedure has been performed.
2. Place 620-ohm resistor across S<sub>O</sub> and +.
3. Place 1.2 kilo-ohm resistor across S<sub>R</sub> and +. The Free Cool LED should be lit.
4. Remove 620-ohm resistor across S<sub>O</sub> and +. The Free Cool LED should turn off.
5. Return EconoMi\$er IV settings and wiring to normal after completing troubleshooting.

**SINGLE ENTHALPY** — To check single enthalpy:

1. Make sure EconoMi\$er IV preparation procedure has been performed.
2. Set the enthalpy potentiometer to A (fully CCW). The Free Cool LED should be lit.
3. Set the enthalpy potentiometer to D (fully CW). The Free Cool LED should turn off.
4. Return EconoMi\$er IV settings and wiring to normal after completing troubleshooting.

**DCV (Demand Controlled Ventilation) AND POWER EXHAUST** — To check DCV and Power Exhaust:

1. Make sure EconoMi\$er IV preparation procedure has been performed.
2. Ensure terminals AQ and AQ1 are open. The LED for both DCV and Exhaust should be off. The actuator should be fully closed.
3. Connect a 9-v battery to AQ (positive node) and AQ1 (negative node). The LED for both DCV and Exhaust should turn on. The actuator should drive to between 90 and 95% open.
4. Turn the Exhaust potentiometer CW until the Exhaust LED turns off. The LED should turn off when the potentiometer is approximately 90%. The actuator should remain in position.
5. Turn the DCV set point potentiometer CW until the DCV LED turns off. The DCV LED should turn off when the potentiometer is approximately 9 v. The actuator should drive fully closed.
6. Turn the DCV and Exhaust potentiometers CCW until the Exhaust LED turns on. The exhaust contacts will close 30 to 120 seconds after the Exhaust LED turns on.
7. Return EconoMi\$er IV settings and wiring to normal after completing troubleshooting.

**DCV MINIMUM AND MAXIMUM POSITION** — To check the DCV minimum and maximum position:

1. Make sure EconoMi\$er IV preparation procedure has been performed.
2. Connect a 9-v battery to AQ (positive node) and AQ1 (negative node). The DCV LED should turn on. The actuator should drive to between 90 and 95% open.
3. Turn the DCV Maximum Position potentiometer to midpoint. The actuator should drive to between 20 and 80% open.
4. Turn the DCV Maximum Position potentiometer to fully CCW. The actuator should drive fully closed.
5. Turn the Minimum Position potentiometer to midpoint. The actuator should drive to between 20 and 80% open.
6. Turn the Minimum Position Potentiometer fully CW. The actuator should drive fully open.
7. Remove the jumper from TR and N. The actuator should drive fully closed.
8. Return EconoMi\$er IV settings and wiring to normal after completing troubleshooting.

**MIXED-AIR INPUT** — To check mixed-air input:

1. Make sure EconoMi\$er IV preparation procedure has been performed.
2. Set the Enthalpy potentiometer to A. The Free Cool LED turns on. The actuator should drive to between 20 and 80% open.
3. Remove the 5.6 kilo-ohm resistor and jumper T to T1. The actuator should drive fully open.
4. Remove the jumper across T and T1. The actuator should drive fully closed.

5. Return EconoMi\$er IV settings and wiring to normal after completing troubleshooting.

**ECONOMI\$ER IV TROUBLESHOOTING COMPLETION** — This procedure is used to return the EconoMi\$er IV to operation. No troubleshooting or testing is done by performing the following procedure.

1. Disconnect power at TR and TR1.
2. Set enthalpy potentiometer to previous setting.
3. Set DCV maximum position potentiometer to previous setting.
4. Set minimum position, DCV set point, and exhaust potentiometers to previous settings.
5. Remove 620-ohm resistor from terminals S<sub>R</sub> and +.
6. Remove 1.2 kilo-ohm checkout resistor from terminals S<sub>O</sub> and +. If used, reconnect sensor from terminals S<sub>O</sub> and +.
7. Remove jumper from TR to N.
8. Remove jumper from TR to 1.
9. Remove 5.6 kilo-ohm resistor from T and T1. Reconnect wires at T and T1.
10. Remove jumper from P to P1. Reconnect device at P and P1.
11. Apply power (24 vac) to terminals TR and TR1.

**Phase Loss Protection** — The phase loss protection option will monitor the three-phase electrical system to provide phase reversal and phase loss protection.

**PHASE REVERSAL PROTECTION** — If the control senses an incorrect phase relationship, the relay (K1) will be de-energized (opening its contact). If the phase relationship is correct, the relay will be energized. The control has a self-bypass function after a pre-set time. If the control determines that the three phases stay in a correct relationship for 10 consecutive minutes, the relay will stay energized regardless of the phase sequence of three inputs as long as 24-vac control voltage is applied. This self-bypass function will be reset if all three phases are restored in a phase loss event.

**PHASE LOSS PROTECTION** — If the reverse rotation board senses any one of the three phase inputs has no AC voltage, the relay will be deenergized (opening its contact). This protection is always active as long as 24-vac control voltage is applied, and is not affected by the self bypass function of the phase sequence monitoring function. However, in the event of phase loss, the relay will be re-energized only if all three phases are restored and the three phases are in the correct sequence.

A red LED is provided to indicate the function of the board. See the table below.

LED STATUS	FUNCTION
<b>On Continuously</b>	Relay contact closed (normal operation).
<b>Blinking</b>	Relay contact open (phase loss or phase reversal has occurred) — No power will be supplied to the control system.
<b>Off</b>	24 vac control power not present (off).





# UNIT START-UP CHECKLIST

MODEL NO.: \_\_\_\_\_

SERIAL NO.: \_\_\_\_\_

DATE: \_\_\_\_\_

TECHNICIAN: \_\_\_\_\_

## I. PRE-START-UP:

- VERIFY THAT ALL PACKING MATERIALS HAVE BEEN REMOVED FROM UNIT
- VERIFY INSTALLATION OF OUTDOOR AIR HOOD
- VERIFY INSTALLATION OF FLUE EXHAUST AND INLET HOOD
- VERIFY THAT CONDENSATE CONNECTION IS INSTALLED PER INSTRUCTIONS
- VERIFY THAT ALL ELECTRICAL CONNECTIONS AND TERMINALS ARE TIGHT
- VERIFY GAS PRESSURE TO UNIT GAS VALVE IS WITHIN SPECIFIED RANGE
- CHECK GAS PIPING FOR LEAKS
- CHECK THAT INDOOR-AIR FILTERS ARE CLEAN AND IN PLACE
- CHECK THAT OUTDOOR AIR INLET SCREENS ARE IN PLACE
- VERIFY THAT UNIT IS LEVEL
- CHECK FAN WHEEL AND PROPELLER FOR LOCATION IN HOUSING/ORIFICE, AND VERIFY SETSCREW IS TIGHT
- VERIFY THAT FAN SHEAVES ARE ALIGNED AND BELTS ARE PROPERLY TENSIONED
- VERIFY THAT SCROLL COMPRESSORS ARE ROTATING IN THE CORRECT DIRECTION
- VERIFY INSTALLATION OF THERMOSTAT
- VERIFY THAT CRANKCASE HEATERS HAVE BEEN ENERGIZED FOR AT LEAST 24 HOURS

## II. START-UP

### ELECTRICAL

SUPPLY VOLTAGE	L1-L2 _____	L2-L3 _____	L3-L1 _____
COMPRESSOR AMPS — COMPRESSOR A1	L1 _____	L2 _____	L3 _____
— COMPRESSOR A2	L1 _____	L2 _____	L3 _____
— COMPRESSOR B1	L1 _____	L2 _____	L3 _____
SUPPLY FAN AMPS	L1 _____	L2 _____	L3 _____

### TEMPERATURES

OUTDOOR-AIR TEMPERATURE	_____	F DB (Dry Bulb)
RETURN-AIR TEMPERATURE	_____	F DB _____ F WB (Wet Bulb)
COOLING SUPPLY AIR	_____	F
GAS HEAT SUPPLY AIR	_____	F

### PRESSURES

GAS INLET PRESSURE	_____	IN. WG
GAS MANIFOLD PRESSURE STAGE NO. 1	_____	IN. WG
REFRIGERANT SUCTION CIRCUIT A	_____	PSIG
CIRCUIT B	_____	PSIG
REFRIGERANT DISCHARGE CIRCUIT A	_____	PSIG
CIRCUIT B	_____	PSIG

STAGE NO. 2 \_\_\_\_\_ IN. WG

- VERIFY REFRIGERANT CHARGE USING CHARGING CHARTS ON PAGE 50

### GENERAL

- ECONOMIZER MINIMUM VENT AND CHANGEOVER SETTINGS TO JOB REQUIREMENTS

CUT ALONG DOTTED LINE

CUT ALONG DOTTED LINE